

INSTRUCTION MANUAL

Serial Number 3487

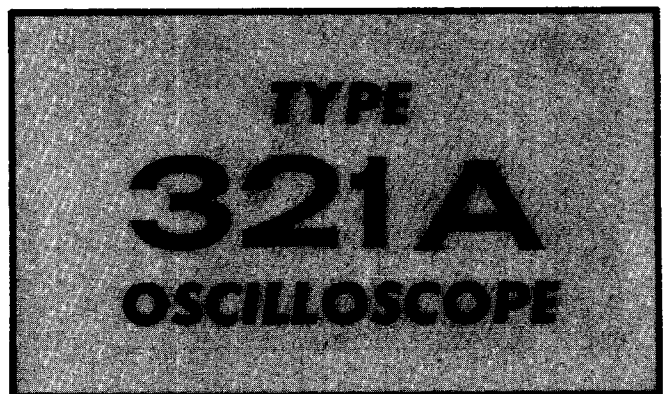

Tektronix, Inc.

S.W. Millikan Way ● P. O. Box 500 ● Beaverton, Oregon 97005 ● Phone 644-0161 ● Cables: Tektronix

070-425

564



WARRANTY

All Tektronix instruments are warranted against defective materials and workmanship for one year. Tektronix transformers, manufactured in our own plant, are warranted for the life of the instrument.

Any questions with respect to the warranty mentioned above should be taken up with your Tektronix Field Engineer.

Tektronix repair and replacement-part service is geared directly to the field, therefore all requests for repairs and replacement parts should be directed to the Tektronix Field Office or Representative in your area. This procedure will assure you the fastest possible service. Please include the instrument Type and Serial number with all requests for parts or service.

Specifications and price change privileges reserved.

Copyright © 1964 by Tektronix, Inc., Beaverton, Oregon. Printed in the United States of America. All rights reserved. Contents of this publication may not be reproduced in any form without permission of the copyright owner.



CONTENTS

	Warranty
Section 1	Characteristics
Section 2	Preliminary Instructions
Section 3	Operating Instructions
Section 4	Circuit Description
Section 5	Maintenance
Section 6	Calibration
Section 7	Parts List and Diagrams

A list of abbreviations and symbols used in this manual will be found on page 7-1. Change information, if any, is located at the rear of the manual.

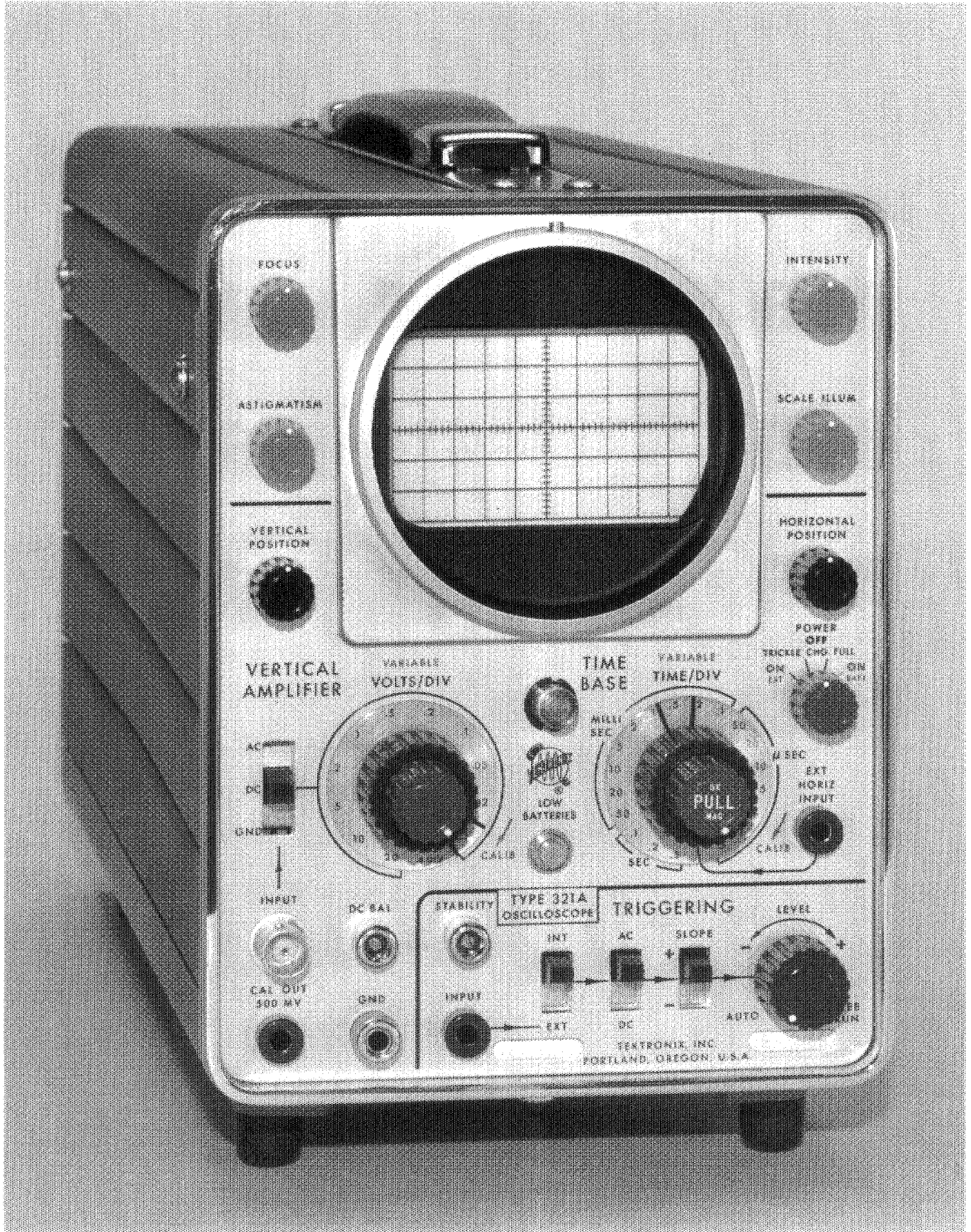

The Type 321A Oscilloscope.

SECTION 1

CHARACTERISTICS

Introduction

The Tektronix Type 321A is a high-performance, dc-to-6 mc, transistorized oscilloscope. Its light weight, small size and ability to operate from a variety of power sources make it a versatile field and laboratory instrument. The oscilloscope can operate from its internally-contained rechargeable battery pack, an external dc source or from a 115/230-volt 50-800 cycle ac line. Regulated power supplies in the instrument, accurate calibration, and precise linearity assure exact time and amplitude measurements despite normal voltage-source and power-supply-load changes that occur under actual operating conditions.

Operating temperature range derived from tests indicates optimum performance and reliability on its self-contained batteries from 0° to +40° C at altitudes up to 15,000 feet. Temperature range without batteries when operating from an external source is -15° C to +55° C. Non-operating temperature range is -55° C to +75° C without batteries and -40° C to +60° C with batteries at altitudes to 50,000 feet.

For the operator's convenience, a front-panel battery light indicates when the internal batteries are low. If external dc or ac operation is being used instead of the batteries, the light turns on if the external voltage source drops too low for proper power supply regulation.

A 4-position power switch on the front panel permits convenient selection of charging rate and/or power source.

Vertical Deflection System

Bandpass—Dc to at least 6 mc (3-db down) using dc coupling; using ac coupling, low-frequency 3-db down point is 2 cps typical from a 1-kc reference.

Sensitivity—0.01 v/div to 20 v/div in 11 calibrated steps; accuracy is within 3% of front-panel markings. Continuously variable from 0.01 v/div to about 50 v/div uncalibrated.

Input Impedance—35 pf nominal paralleled by 1 megohm ($\pm 1\%$), 8.2 pf nominal paralleled by 10 megohms ($\pm 2\%$) when using the P6006 10 \times Probe.

Maximum Allowable Input Voltage Rating—600 volts combined dc and peak ac; 600 volts (not 1200 volts) peak-to-peak ac.

Triggering

Type—Automatic, or amplitude-level selection using pre-set stability.

Mode—Ac-coupled or Dc-coupled.

Slope—Plus, from rising slope of triggering waveform, or minus from negative slope of triggering waveform.

Source—Internal from vertical signal, or external from triggering signal.

Signal Requirements—Internal: 0.2 major division vertical deflection at 1 kc increasing to 1 major division at 6 mc.

External: 1 volt peak-to-peak at 1 kc increasing to 3 volts peak-to-peak at 6 mc. Nominal input impedance: 5 pf paralleled by 100 kilohms ($\pm 20\%$).

Sweep

Type—Miller Integrator.

Sweep Rates—0.5 μ sec/div to 0.5 sec/div in 19 calibrated steps. Accurate 5 \times sweep magnifier extends calibrated range to 0.1 μ sec/div. Calibrated sweep-rate accuracy is $\pm 3\%$. Sweep time adjustable between steps and to ≥ 1.5 sec/div uncalibrated.

External Horizontal Input

Bandpass—Dc to at least 1 mc (3-db down).

Deflection Factor—1 v/div $\pm 10\%$ with 5 \times magnifier on.

Input Impedance—30 pf typical paralleled by 100 kilohms ($\pm 5\%$).

Amplitude Calibrator

Square Wave—Frequency about 2 kc.

Amplitude—500 mv peak-to-peak. Also 40 mv peak-to-peak internally coupled in CAL 4 DIV position of VOLTS/DIV switch. Peak-to-peak amplitude accuracy is $\pm 3\%$.

Cathode-Ray Tube

Type—Special Tektronix-manufactured T3211. 3" flat-face, post-deflection accelerator. Low heater power.

Accelerating Potential—4 kv.

Z-Axis Modulation—External terminal permits RC coupling to crt grid.

Unblinking—Deflection unblinking.

Phosphor—Type P31 normally furnished; P1, P2, P7, and P11 phosphors optional. Other phosphors furnished on special order.

Graticule

Illumination—Variable edge lighting when operating from ac line.

Display Area—Marked in 6-vertical and 10-horizontal $\frac{1}{4}$ " divisions.

Power Requirements

Source—Operates from 10 size D flashlight cells, or 10 size D rechargeable cells (approximately 3 hours using 2.5 ampere-hour cells; approximately 5 hours using 4

Characteristics — Type 321A

ampere-hour cells), or 11.5 to 35 volts dc (aircraft, auto, boat, etc.), or 103.5 to 126.5 volts or 207 to 253 volts, rms, 50 to 800 cycles, single-phase ac.

Power Consumption—Approximately 700 ma from internal batteries or external dc source; 20 watts nominal at 115-volt ac line.

Temperature Protection—Thermal cutout switch interrupts power if ambient temperature exceeds 131° F (55° C).

Built-in battery charger is standard equipment.

Environmental Capabilities

Vibration (operating)—0.025" peak-to-peak, 10 to 55 to 10 cps in 1 minute sweeps (4 G's) for 15 minutes on each axis. Three-minute vibration at resonance or 55 cps on each axis.

Shock (operating)—20 G's, $\frac{1}{2}$ sine, 11-msec duration. Two shocks each direction along each of the three major axis: bottom, top, left side, right side, front and rear. Total of 12 shocks.

Shock (non-operating)—60 G's, $\frac{1}{2}$ sine, 11-msec duration. One shock each direction along each of the three major axis; total of 6 shocks.

Humidity (non-operating)—Meets Mil-Std-202B, method 106A (except freezing and vibration) through 5 cycles (120 hours).

Transit (non-operating)—Meets National Safe Transit test when factory packaged. Vibration for one hour at slightly greater than one G. Eighteen-inch drop in any orientation.

Mechanical Specifications

Construction—Aluminum alloy chassis and cabinet.

Finish—Anodized panel, blue vinyl-finish cabinet.

Dimensions—8 $\frac{1}{2}$ " high, 5 $\frac{3}{4}$ " wide, 16" deep overall.

ACCESSORIES

Information on accessories for use with this instrument is included at the rear of the mechanical parts list.

SECTION 2

PRELIMINARY INSTRUCTIONS

Power Requirements

The regulated power supplies in the Type 321A will operate from 115-v or 230-v rms ac line, from an external dc source (11.5 to 35 volts), or from a "battery pack" consisting of either 10 size D flashlight cells or 10 size D rechargeable cells.

Fuse Data

Use only the recommended fuses in the Type 321A Oscilloscope. The upper fuse, F621 (see Fig. 2-1), is a 1.5-amp 3AG Fast-Blo; the lower fuse, F601, is a .25-amp 3AG Fast-Blo. Neither fuse needs to be changed if the oscilloscope is converted from one line voltage to the other (115 v and 230 v).

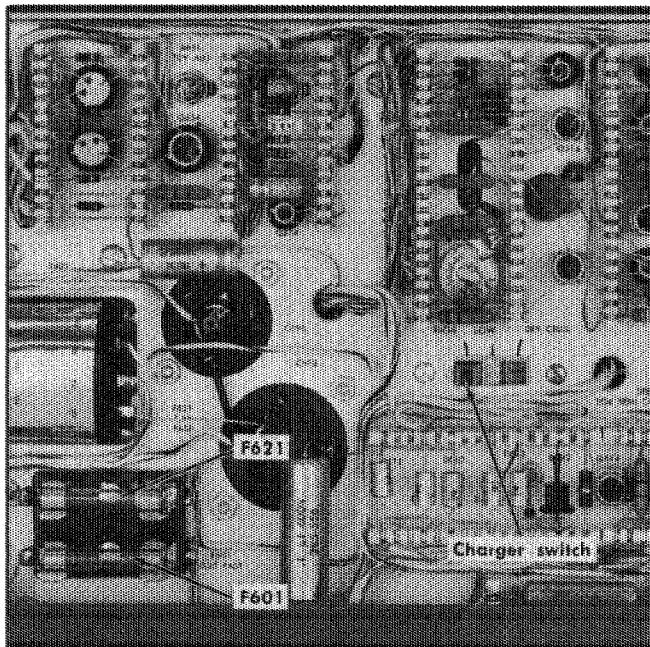

Fig. 2-1. Location of fuses and Charger switch (left-side view).

Ac Operation

Unless tagged otherwise, your instrument is connected at the factory for operation at 103.5 to 126.5 volts, 50 to 800 cycles ac (115 volts nominal). However, provisions are made for easy conversion to operate at 207 to 253 volts, 50 to 800 cycles (230 volts nominal). The power transformer T601 is provided with split input windings which are normally connected in parallel for 115-volt operation, but which can be connected in series for 230-volt operation.

The primary windings are marked 1, 2, 3, and 4. Terminals 1 and 3 are connected to one winding and terminals 2 and 4 are connected to the second winding. The ac input leads are connected to terminals 1 and 4 for both 115-volt and 230-

volt operation, so these connections do not have to be changed when converting from one line voltage to the other.

When wired for 115-volt operation, terminals 1 and 2 are joined by a bare bus wire, and terminals 3 and 4 are similarly joined, as shown in Fig. 2-2(a). To convert to 230-volt operation, remove the bare bus wires between these terminals and substitute a single connecting wire between terminals 2 and 3, as shown in Fig. 2-2(b).

To turn on the Type 321A when the power cord is connected to the oscilloscope power connector and to the ac voltage source, set the POWER switch to EXT ON. To turn off the oscilloscope, set the POWER switch to TRICKLE. The TRICKLE position can be regarded as the normal "off" position for the instrument.

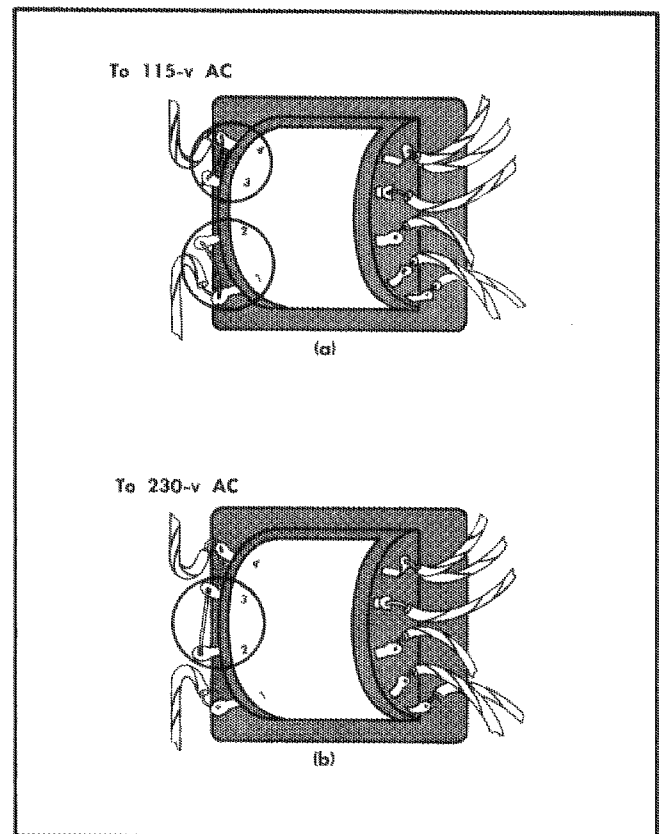

Fig. 2-2. (a) Transformer connection for operation from 103.5-126.5 volt ac line; (b) connections for operation from 207-253 volt ac line.

As long as the ac power cord is connected to the ac line, power is being applied to the power transformer T601, ac-rectifier circuit, and graticule lights for all positions of the POWER switch. Application of power to these circuit is required to provide battery-charger operation for the internal batteries; the graticule lights provide visual indication that these circuits are "on". Power to the battery charger itself is controlled by a Charger switch (see Fig. 2-1). If the switch

Preliminary Instructions — Type 321A

is set to LOW or HIGH, the ac rectifier is connected to the battery charger circuit which, in turn, provides charging current to the internal rechargeable batteries.

NOTE

If dry cells are used instead of rechargeable batteries, then the Charger switch must be set to DRY CELLS to disconnect the charger circuit. For further information about battery operation, refer to the topics titled "Battery Operation" and "Battery Charger" appearing in this section of the manual.

If the Type 321A is being operated exclusively from the ac line and the internal batteries are removed, the Charger switch can remain in the DRY CELLS position to disconnect the charger circuit. If you prefer to completely turn off all power to the Type 321A, set the POWER switch to TRICKLE and either disconnect the power cord from the ac line or turn off the power at a wall switch (or equivalent).

Battery Operation

Operation from the internal battery source can be accomplished by using:

1. Ten size D flashlight cells (approximately 1/2-hour continuous operation, more with intermittent operation), or
2. Ten size D Alkaline cells such as Eveready E95, Burgess AL-2, or Mallory MN-1300 (about 2 1/2 hours continuous operation), or
3. Ten size D nickel-cadmium rechargeable cells (up to about 5 hours continuous operation, depending on the type used).

The nickel-cadmium cells are the most practical type where considerable battery operation is planned.

To install the cells, first open the battery cover as illustrated in Fig. 2-3. Next, install the batteries by following the procedure given in Fig. 2-4.

CAUTION

Be sure to observe cell polarity indicated on the battery cover.

To turn on the Type 321A when operating from the internal batteries, set the POWER switch to BATT ON. To turn off the oscilloscope, set the POWER switch to one of the OFF positions—FULL or TRICKLE. These OFF positions disconnect the batteries from the oscilloscope load (10-volt regulated supply) so there is no battery drain. To charge the rechargeable batteries, refer to the next topic titled "Battery Charger".

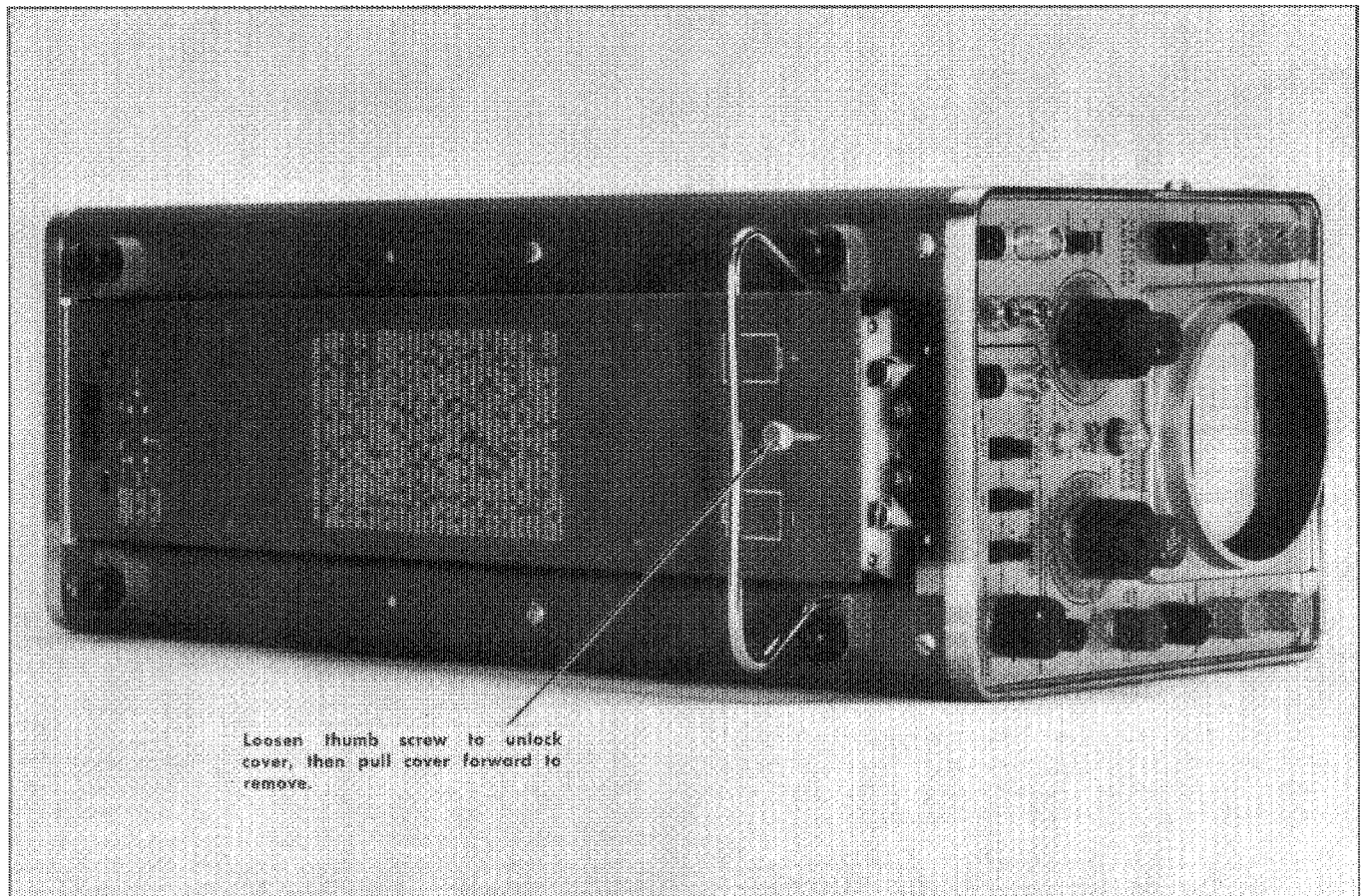

Fig. 2-3. Removing the battery cover from the Type 321A Oscilloscope.

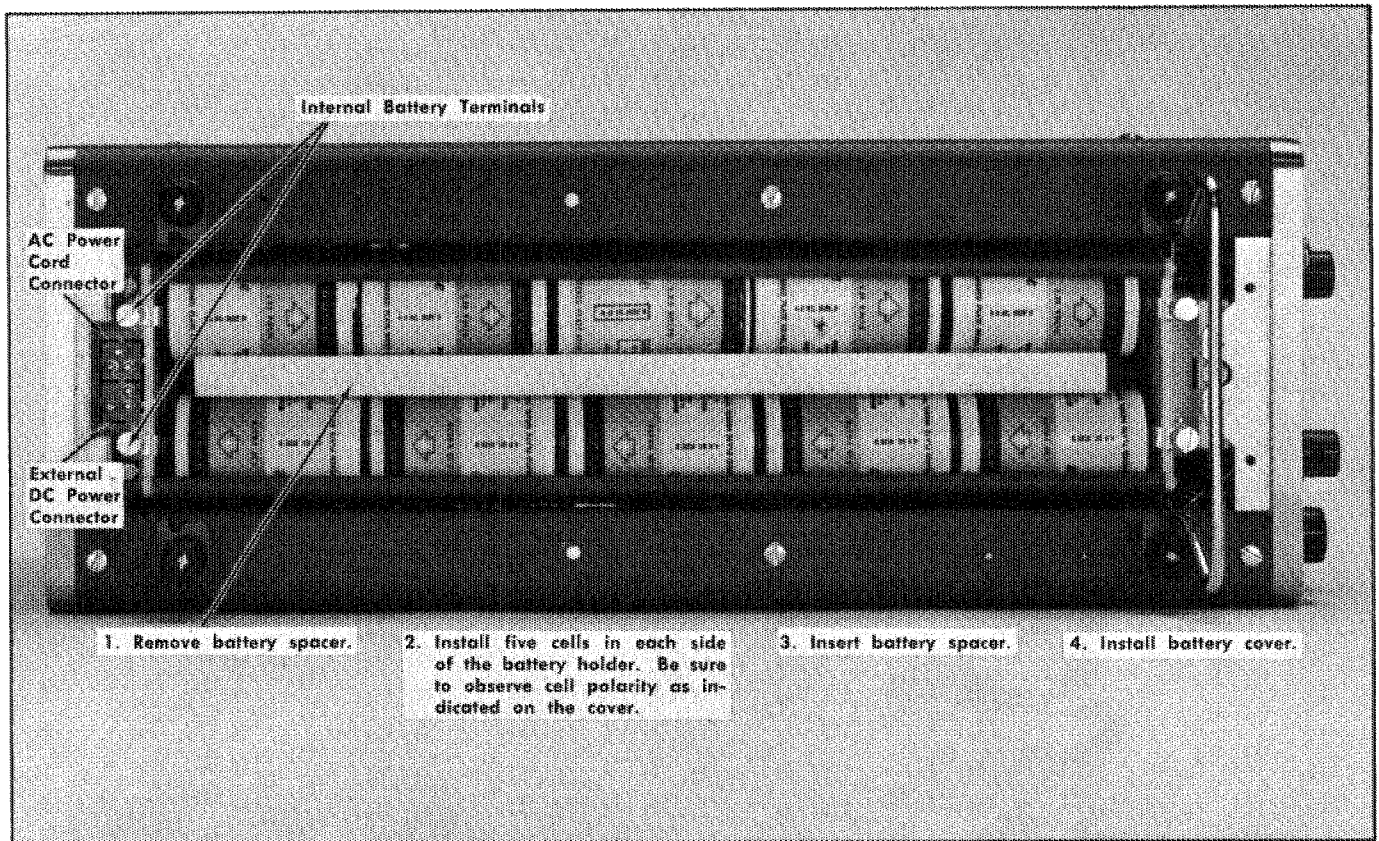

Fig. 2-4. Procedure for installing the batteries.

Battery Charger

As mentioned previously, the battery charger is connected to the internal batteries as long as the ac power cord is connected to an ac power source and the Charger switch (see Fig. 2-1) is set to HIGH or LOW. No charging occurs if the Charger switch is set to DRY CELLS.

Table 2-1 summarizes the charging currents that can be obtained by using various line voltages in combination with various settings of the POWER and Charger switches. The table shows the Type 321A wired for 115-volt nominal line operation. If the oscilloscope is wired for 230-volt nominal line operation, the charging currents will still be the same but the ac line voltages will be twice the amount shown in the table.

Use Table 2-1 as an aid in determining the proper position for the POWER and Charger switches for the particular brand or type of rechargeable batteries being used in the Type 321A. After setting the switches to their proper position, the line voltage can then be set to the charging rate recommended by the manufacturer of the cells. An auto-transformer having a rating of at least 1 ampere and equipped with an rms-reading ac voltmeter can be used to set the line voltage.

When using rechargeable batteries, sixteen hours of charging at the full rated charging current recommended by the manufacturers should be adequate to fully charge the batteries. Excess charging may damage the batteries.

One method for determining charge conditions of the batteries is to set the POWER switch to BATT ON and then measure the voltage across the battery terminals (see Fig. 2-4). A reading higher than 13 volts indicates that the batteries are fully charged. A reading lower than 13 volts indicates that more charging time is required.

As mentioned previously, if dry cells are installed in the battery holder and the Type 321A is being operated from the ac line, the Charger switch must be set to the DRY CELLS position. This position disconnects the charging circuit from the batteries.

TABLE 2-1
Charging Currents

POWER* Switch Position	Charger Switch Position	Approximate Charging Current in Ma				
		103.5 v	109 v	115 v	121 v	126.5 v
EXT ON	LOW	20	24	27	31	33
	HIGH	22	26	30	33	35
TRICKLE	LOW	31	34	38	41	44
	HIGH	34	37	41	44	48
FULL	LOW	160	180	200	220	230
	HIGH	290	320	360	380	410

*The BATT ON position is not included in the table because the Type 321A should not be operated from the ac line and the batteries at the same time. Reason: Battery drain exceeds charging rate.

Dc Operation

Operation from an external dc source is accomplished by connecting the special pigtail-type dc power cord in the proper manner. For 11.5- to 20-volt operation, the black (+) and white (—) leads are connected to the voltage source; for 20- to 35-volt operation, the green (+) and white (—) leads are connected to the voltage source. When the connections to the external dc voltage source are properly made, the external dc source is floating with respect to the Type 321A chassis. Up to 600 volts difference is permissible, if necessary.

To turn on the Type 321A, set the POWER switch to EXT ON. To turn off the oscilloscope, set the POWER switch to one of the OFF positions—TRICKLE or FULL.

When operating from the external dc source, the ac line cord should be disconnected. That is, only one of the external sources should be used rather than both at the same time.

NOTE

The internal battery charger circuit is disconnected during external dc operation. Therefore, external batteries (if used as the dc source) cannot be charged by connecting the line cord to the ac line. Also, an external dc source cannot be used to charge the internal batteries since the POWER switch does not electrically connect the two sources together.

LOW BATTERIES Light

The LOW BATTERIES light turns on when the following conditions exist:

1. The POWER switch is set to BATT ON and the internal batteries drop to 11.5 v (± 0.2 v) or lower.
2. The POWER switch is set to EXT ON and the external source voltage is low enough to cause the Type 321A unregulated voltage to drop to about 11.5 v or lower.

SECTION 3

OPERATING INSTRUCTIONS

General Information

The Type 321A Oscilloscope is an extremely versatile instrument, adaptable to a great number of applications. However, to make full use of the instrument, it is necessary that you understand completely the operation of each front-panel control. This portion of the manual is intended to provide you with the basic information you require. If you are familiar with other Tektronix oscilloscopes, you should have very little difficulty in understanding the operation of the Type 321A. The function of many controls is the same as the function of corresponding controls on other Tektronix instruments. A front-panel view of the Type 321A is shown in Fig. 3-1.

Intensity Control

The INTENSITY control is used to adjust the trace brightness. This permits adjustment of trace intensity to suit the ambient light conditions and changes in intensity caused by changes in the sweep triggering rate (sweep duty cycle). Clockwise rotation increases the intensity and counterclockwise rotation decreases the intensity.

Focus and Astigmatism Controls

The FOCUS and ASTIGMATISM controls operate in conjunction with each other to allow you to obtain a sharp, clearly defined spot or trace. To adjust these controls:

1. Adjust the INTENSITY control for the most pleasing level.
2. Set the ASTIGMATISM control to midscale.
3. Adjust the FOCUS control for sharpest detail.
4. Adjust the ASTIGMATISM control as necessary for best overall focus.

Graticule Illumination Control

The graticule used with the Type 321A is accurately marked with 10 horizontal and 6 vertical divisions, with 0.2-division markers on the centerlines. These graticule markings allow you to obtain time and voltage measurements from the oscilloscope screen.

Graticule illumination is adjusted by the SCALE ILLUM control, located just to the right of the oscilloscope screen. Rotating the control clockwise increases the brightness of the graticule markings and counterclockwise rotation decreases the brightness.

NOTE

The graticule is illuminated only when operating from an ac line. This permits longer operation when on batteries.

Positioning Controls

Two controls are used with the Type 321A Oscilloscope to position the trace or spot on the screen.

The HORIZONTAL POSITION control moves the trace to the right when it is rotated clockwise and to the left when it is rotated counterclockwise. This control has a positioning range of approximately 15 divisions with the sweep magnifier off, and approximately 75 divisions with the sweep magnifier on.

The HORIZONTAL POSITION control is a combination coarse/vernier type of control. Built-in backlash between its two sections permits 30° of vernier adjustment for a given coarse setting. If a 30° range is exceeded, the coarse adjustment takes over to provide fast positioning of the trace.

The VERTICAL POSITION control has sufficient range to position the trace completely off the top or bottom of the screen, or to any intermediate point. The trace moves up when the control is rotated clockwise and down with the counterclockwise rotation.

Intensity Modulation

The crt display of the Type 321A Oscilloscope can be intensity modulated by an external signal to display additional information. This is accomplished by disconnecting the grounding bar from the CRT GRID connector at the rear of the instrument and connecting the external signal to this terminal. A negative signal of approximately 30 volts peak is required to cut off the beam from maximum intensity, less with lower intensity levels. Negative-going signals as low as 5 volts peak will accomplish intensity modulation.

HORIZONTAL DEFLECTION SYSTEM

Horizontal Sweep

The usual oscilloscope display is a graphical presentation of instantaneous voltage versus time. Voltage is represented by vertical deflection of the trace and time is represented by horizontal deflection. To obtain a useful display, the spot formed by the electron beam is deflected horizontally at a known rate, so that any horizontal distance on the screen represents a definite known period of time. The trace formed by the deflection of the spot across the screen is known as the horizontal sweep. Since the horizontal deflection of the spot bears a definite relationship to time, and provides the means for making time measurements from the screen, the horizontal sweep is also known as the time base. (See Fig. 3-2).

The rate at which the spot is deflected across the screen is accurately controlled by the setting of the TIME/DIV control. The setting of the TIME/DIV control determines the sweep rate, and thus the number of cycles displayed on the crt screen. The control is set to display the portion of the waveform you wish to observe.

CRT CONTROLS

FOCUS — Controls sharpness of spot or trace.

ASTIGMATISM—Used in conjunction with FOCUS to obtain overall focus.

INTENSITY—Controls brightness of trace.

SCALE ILLUM—Adjusts brightness of graticule markings (when operating from AC line).

VERTICAL CONTROLS

VERTICAL POSITION — Positions trace vertically.

AC-DC-GND—Selects either AC or DC input coupling. The GND position connects the Vertical Amplifier to ground but does not ground the input signal.

VOLTS/DIV and VARIABLE — Selects vertical deflection factor and calibrator signal.

INPUT — Terminal for accepting waveforms to be displayed on crt.

CAL OUT 500 MV—Terminal provides 500-mv square wave for compensating probe.

DC BAL—Potentiometer for setting dc balance of Vertical Amplifier.

HORIZONTAL CONTROLS

HORIZONTAL POSITION—Coarse-vernier type of control that positions trace horizontally.

POWER—Switch turns regulated 10-volt power on and off. Also, selects charging rate.

TIME/DIV and VARIABLE—Selects sweep rate and external horizontal input.

EXT HORIZ INPUT—Terminal for accepting external horizontal signal.

TRIGGERING CONTROLS

LEVEL—Selects point on triggering signal at which sweep is triggered.

SLOPE—Determines whether sweep is triggered on + or - slope of triggering signal.

AC-DC—Selects AC or DC coupling for triggering signal.

INT-EXT—Selects either internal or external triggering signal.

STABILITY—Potentiometer for setting dc level of sweep generator.

INPUT—Terminal for accepting external triggering signal.

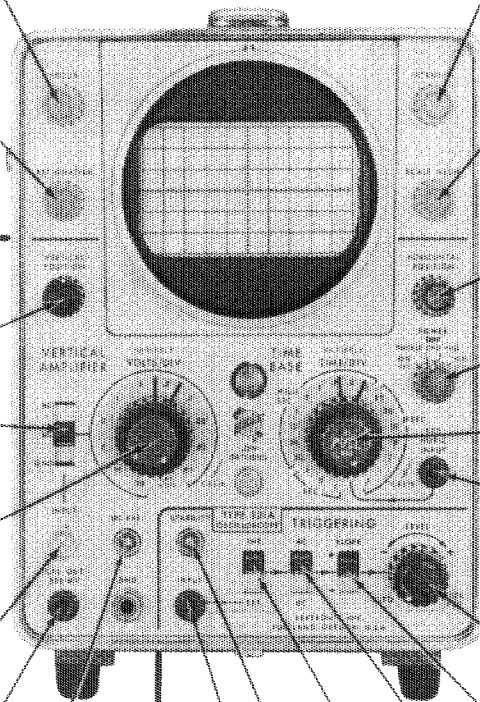

Fig. 3-1. Functions of the Type 321A Oscilloscope front-panel controls.

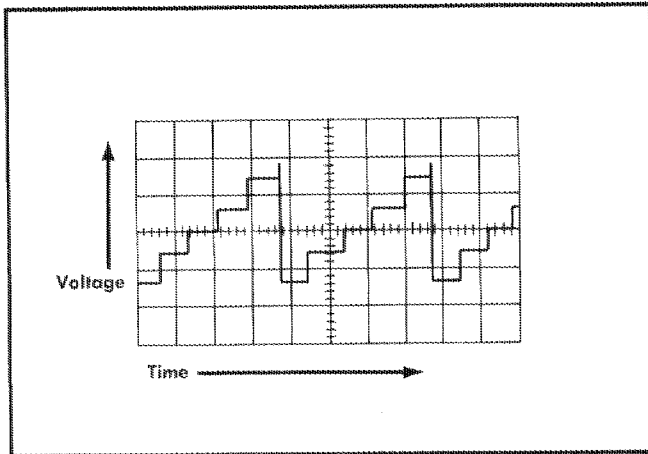

Fig. 3-2. The oscilloscope plots instantaneous voltage versus time, thereby serving both as a voltmeter and a timer.

The Time Base has 19 accurately calibrated sweep rates ranging from $.5 \mu\text{sec/div}$ to $.5 \text{sec/div}$. These calibrated sweep rates are obtained when the VARIABLE (TIME/DIV) control is fully clockwise in the CALIB position. The TIME/DIV switch selects the calibrated sweep rates and can be rotated 360° since there are no mechanical stops. The VARIABLE control permits you to vary the sweep rate continuously between $.5 \mu\text{sec/div}$ and approximately 1.5sec/div . All sweep rates obtained with the VARIABLE control in any position other than fully clockwise are uncalibrated.

Sweep Magnifier

The sweep magnifier allows you to expand any two-division portion of the displayed waveform to the full ten-division width of the graticule. This is accomplished by first using the HORIZONTAL POSITION control to move the portion of the display you wish to expand to the center of the graticule, then placing the $5\times$ MAG switch in the "on" position (pull out the red VARIABLE TIME/DIV knob; see Fig. 3-3). Any portion of the display magnified by the horizontal sweep can then be observed by rotating the HORIZONTAL POSITION control.

In magnified sweep operation, the sweep rate indicated by the position of the TIME/DIV switch must be divided by 5 to obtain the actual time required for the spot to move one division. For example, if the TIME/DIV switch is set to 5 MILLI SEC, the actual time per division is 5 milliseconds divided by 5, or 1 millisecond per division. The actual time-per-division must be used for all time measurements.

External Horizontal Input

For special applications you can deflect the trace horizontally with some externally derived waveform rather than by means of the internal sweep sawtooth. This allows you to use the oscilloscope to plot one function versus another.

To use the external horizontal input, connect the externally derived waveform to the EXT HORIZ INPUT connector and place the TIME/DIV switch in the EXT position. The horizontal deflection factor is approximately 1 volt/division with the $5\times$ MAG on.

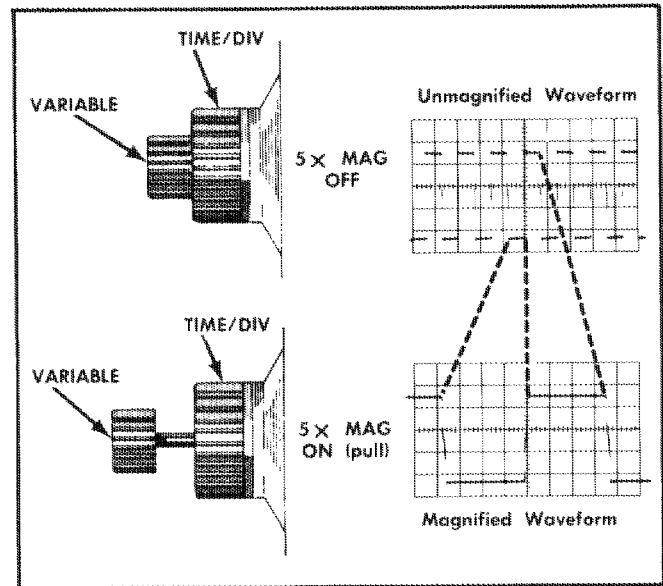

Fig. 3-3. Operation of the sweep magnifier.

Sweep Triggering

The oscilloscope display is formed by the repetitive sweep of the spot across the oscilloscope screen. If the sweeps are allowed to occur at random, or a rate unrelated to the input waveform, the displayed waveform will be traced out at a different point on the screen with each sweep. This will either cause the waveform to drift across the screen or to be indistinguishable.

In most cases it is desirable for repetitive waveforms to appear stationary on the oscilloscope screen so that the characteristics of the waveform can be examined in detail. As a necessary condition for this type of display, the start of the sweep must bear a definite, fixed-time relationship to the observed waveform. This means that each sweep must start at the same time, relative to some point on the observed waveform. In the Type 321A, this is accomplished by starting or triggering the sweep with the displayed waveform, or with another waveform bearing a definite time relationship to the displayed waveform.

The waveform used to start the horizontal sweep is called a "triggering signal" (whether it is the waveform being observed, or some other waveform). The following instructions tell you how to select the triggering signal source.

Selecting the Triggering Source

In preparing the Type 321A Oscilloscope for triggered operation of the sweep, it is first necessary to select the triggering signal source which will provide the best display for the particular application. The sweep can be triggered by the displayed waveform, or by an externally derived waveform. This selection is made by the setting of the INT-EXT switch (see Fig. 3-4). Each type of triggering has certain advantages for some applications.

Triggering from the displayed waveform is the method most commonly used. The displayed waveform is selected when the INT-EXT switch is in the INT position. Internal trig-

Operating Instructions — Type 321A

gering is convenient since no external triggering connections are required. Satisfactory results are obtained in most applications.

To trigger the sweep from some external waveform, connect the triggering waveform to the (TRIGGERING) INPUT connector and place the INT-EXT switch in the EXT position. (External triggering provides definite advantages over internal triggering in certain cases.) With external triggering, the triggering signal usually remains constant in amplitude and shape. It is thereby possible to observe the shaping and amplification of a signal in an external circuit without resetting the oscilloscope triggering controls for each observation. Also, time and phase relationships between the waveforms at different points in the circuit can be seen. If, for example, the external triggering signal is derived from the waveform at the input to a circuit, the time relationship and phase of the waveforms at each point in the circuit are compared to the input signal by the display presented on the oscilloscope screen.

Selecting the Triggering Slope

The horizontal sweep can be triggered on either the rising or falling portion of the triggering waveform. When the SLOPE switch is in the + position, the sweep is triggered on the rising portion of the triggering waveform; when the

SLOPE switch is in the — position, the sweep is triggered on the falling portion of the waveform (see Fig. 3-5).

In many applications the triggering slope is not important since triggering on either slope will provide a display suitable to the application.

Selecting the Triggering Mode

Automatic Mode

Automatic triggering is obtained by rotating the (TRIGGERING) LEVEL control fully counterclockwise to the AUTO position.

This mode allows triggering at the average voltage point of the applied waveform. Also, the sweep runs at approximately a 50-cycle rate when no triggering signals are applied; this produces a reference trace or baseline on the screen. Automatic triggering can be used with both internal and external triggering signals, but for most waveforms it is useful only for triggering at frequencies above 50 cycles. Automatic triggering saves considerable time in observing a series of waveforms since it is not necessary to reset the triggering level for each observation. For this reason it is the mode that is normally used. Other modes are generally used only for special applications, or where stable triggering is not attainable in the automatic mode.

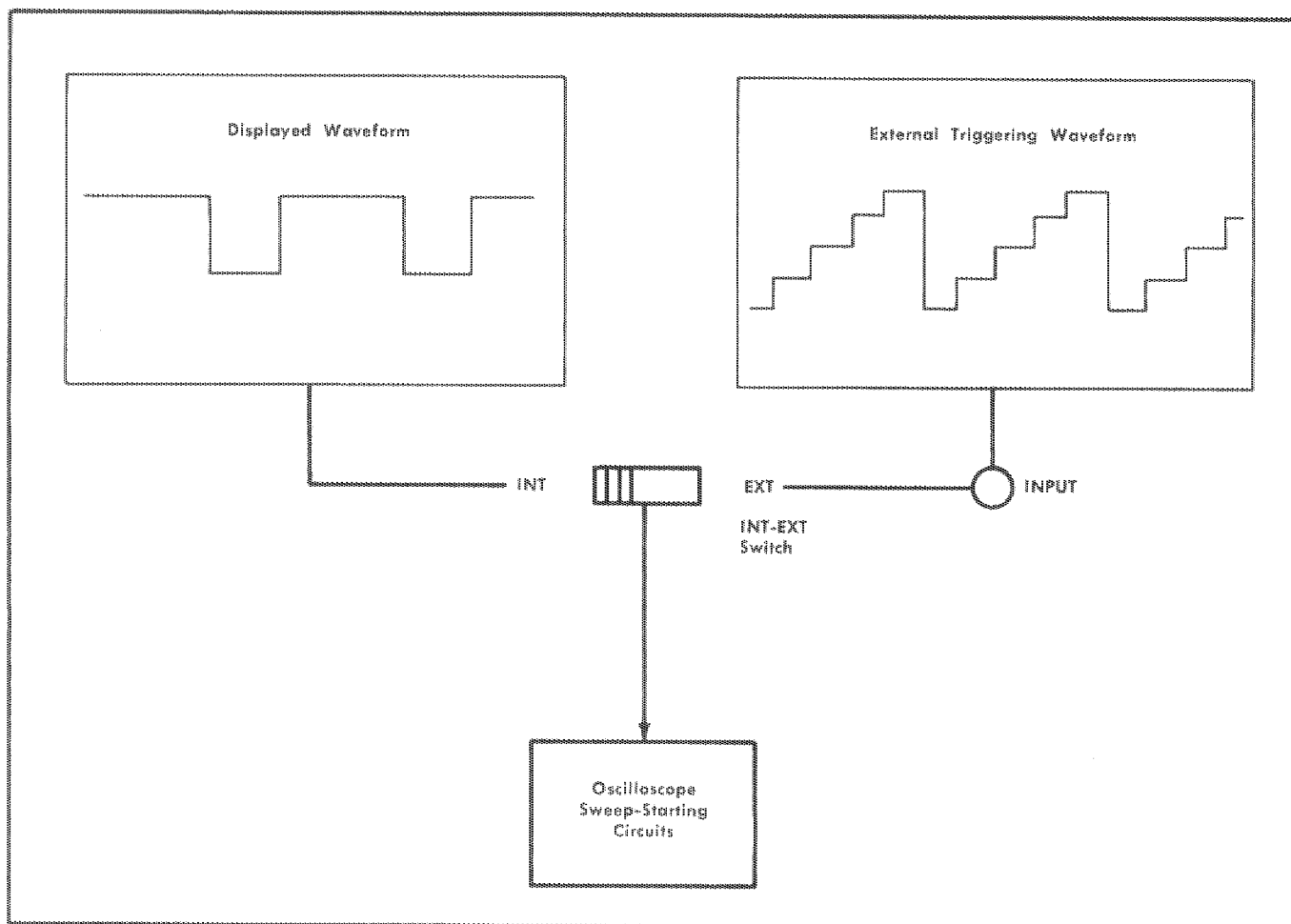

Fig. 3-4 The triggering signal is selected from two possible sources with the INT-EXT switch.

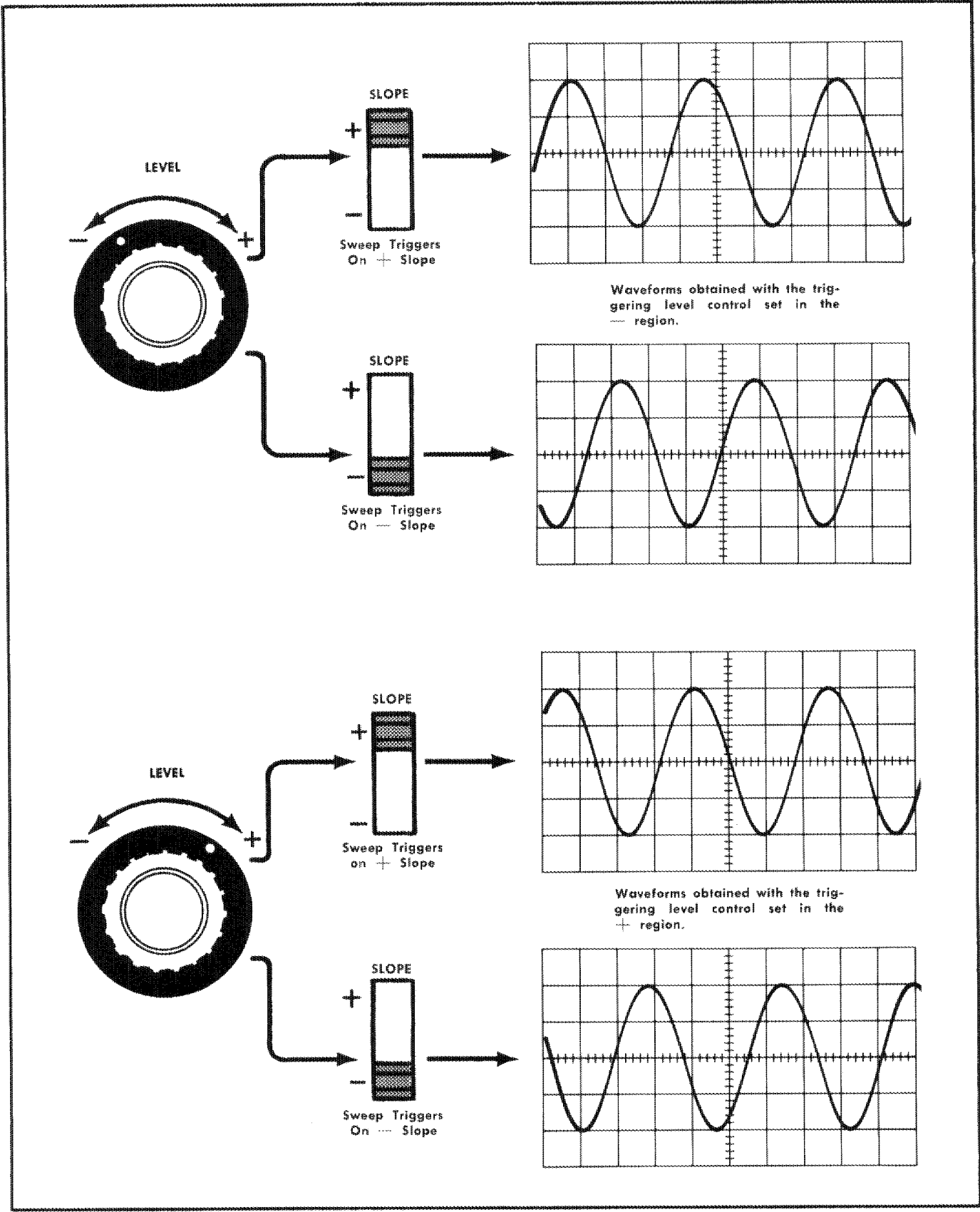

Fig. 3-5. Effects on the oscilloscope display produced by + and - settings of the SLOPE and LEVEL controls.

Operating Instructions — Type 321A

Ac Mode

Ac-mode triggering is obtained by setting the AC-DC switch to the AC position. This mode provides stable triggering on virtually all types of waveforms. As a general rule, however, the ac mode is unsatisfactory for triggering with low amplitude waveforms at frequencies below approximately 15 cycles. This figure will vary depending upon the amplitude and shape of the triggering waveform and should not therefore be set as an absolute standard. Triggering at frequencies below 15 cycles can be accomplished when higher amplitude triggering signals are used.

In the ac mode, the triggering point depends on the average voltage level of the triggering signals. If the triggering signals occur at random, the average voltage level will vary causing the triggering point to vary also. This shift of the triggering point may be enough so that it is impossible to maintain a stable display. In such cases you should use the dc mode.

Dc Mode

Dc mode triggering is obtained by setting the AC-DC switch to the DC position. This mode of triggering is particularly useful in triggering from waveforms which are not adaptable to the ac mode, such as random pulse trains or very low-frequency waveforms. Random pulse trains pose a special problem in the ac mode since the random occurrence of the input waveforms causes the average voltage level to shift. This in turn may cause the triggering level to shift to an unstable point. This problem is not encountered in the dc mode since the triggering point is determined only by instantaneous voltages.

In the dc mode, when the triggering signal is obtained from the Vertical Amplifier, varying the VERTICAL POSITION control will change the triggering point. For this reason, you may find it necessary to readjust the LEVEL control when you change the vertical position of the trace. To eliminate this effect, you can use the ac mode provided the triggering signal is otherwise suitable for this mode of operation. In the dc mode, the dc level of the external triggering signals will also effect the triggering point. Generally, when the triggering signal is small compared to its dc level, the ac mode should be used.

How to Set the Triggering Level

In the ac and dc triggering modes, the LEVEL control determines the voltage level on the triggering waveform at which the sweep is triggered. Using this control, the sweep can be continuously triggered at any point on the waveform so long as the slope of the waveform is great enough to provide stable triggering. In the dc mode, the sweep cannot be triggered with any degree of stability at the top of a square wave, for example, because the time that the voltage remains constant is comparatively long. As a result, the sweep triggers at random points along the top of the square wave, producing considerable trace jitter.

You can use the same method to set the LEVEL control for either the ac or dc mode. After selecting the triggering slope, rotate the LEVEL control fully counterclockwise to the AUTO position. Then rotate the LEVEL control clockwise until the sweep no longer triggers. Continue to rotate the

control in the clockwise direction until the sweep again triggers and a stable display is obtained. Further rotation of the control in the clockwise direction causes the sweep to trigger at more positive points on the triggering waveform. In the fully clockwise direction the trace will free run (Fig. 3-5).

FREE-RUNNING OPERATION

With the Type 321A, you can get a periodic, free-running sweep, independent of any external triggering or synchronizing signal, by rotating the LEVEL control fully clockwise to the FREE RUN position. This permits you to observe the trace without an input signal. This trace can then be used to position the sweep or to establish a voltage reference line. The difference between the traces produced in the AUTO position and the FREE RUN position is the repetition rate. The repetition rate in the FREE RUN position is dependent upon the setting of the timing switch. The repetition rate in the AUTO position is fixed at approximately 50 cycles. At the faster sweep rates, the trace in the AUTO position will appear to be dim. In the FREE RUN position the trace intensity remains essentially constant for all sweep rates.

VERTICAL DEFLECTION SYSTEM

Input Coupling

Input signals to the Vertical Amplifier can be either ac- or dc-coupled by placing the AC-DC-GND switch in the appropriate AC or DC position. Dc coupling applies both the ac and dc components of the input signal to the vertical amplifier circuit. This permits measurement of the dc voltage level as well as the amplitude of the ac component. It is sometimes neither necessary nor desirable to display the dc component, however, and in such cases as coupling should be used. This is accomplished by setting the AC-DC-GND switch to AC. With ac coupling, a capacitor is placed in series with the input connector to block the dc component while allowing the ac component to be displayed.

Placing the AC-DC-GND switch to the GND position grounds the input circuit of the vertical amplifier to provide a dc zero reference. In this position the switch internally disconnects, but does not ground, the applied signal to the input connector. Thus, the GND position eliminates the usual need for externally grounding the (Vertical Amplifier) INPUT connector of the Type 321A or the probe tip to establish a ground reference.

Deflection Factor

The electrical waveform to be observed is applied to the (Vertical Amplifier) INPUT connector. The waveform is then applied through the vertical-deflection system to cause the spot to be deflected vertically to trace out the waveform on the screen of the crt. The VOLTS/DIV switch controls the vertical deflection factor in accurately calibrated steps. The VARIABLE control provides uncalibrated variable deflection factors between the fixed steps of the VOLTS/DIV switch. The VARIABLE control has 360° rotation range and a detent position when the control is set to CALIB.

NOTE

To make the deflection factor equal to that indicated by the VOLTS/DIV switch, set the VARIABLE control to the CALIB detent position.

Dc Balance Adjustment

The need for adjustment of the DC BAL control is indicated by a vertical shift in the position of the trace as the VARIABLE (VOLTS/DIV) control is rotated. This adjustment should be made as follows:

1. Set the AC-DC-GND switch to GND.
2. Set the oscilloscope controls for a free-running trace.
3. Rotate the VARIABLE (VOLTS/DIV) control back and forth, and adjust the DC BAL control simultaneously until the trace position is no longer affected by rotation of the VARIABLE control.

Input Signal Connections

Certain precautions must be observed when you are connecting the oscilloscope to an input signal source. This is to insure that accurate information is obtained from the oscilloscope display. This is particularly true when you are observing low-level signals, or waveforms containing high- or extremely low-frequency components. For applications where you are observing low-level signals, shielded cables should be used whenever possible, with the shield connected to the chassis of both the oscilloscope and the signal source. Unshielded input leads are generally unsatisfactory due to their tendency to pick up stray signals which produce erroneous oscilloscope displays. Regardless of the type of input used, the leads should be kept as short as possible.

Distortion of the input waveform may result if:

1. Very low-frequency input signals are ac-coupled to the oscilloscope.
2. High-frequency waveforms are not properly terminated.
3. The input waveform contains high-frequency components which exceed the bandpass of the oscilloscope.

You must be aware of the limitations of the instrument.

In analyzing the displayed waveform, you must consider the loading effect of the oscilloscope on the input signal source. In most cases this loading effect is negligible; however, in some applications loading caused by the oscilloscope may materially alter the results obtained. In such cases you may wish to reduce the amount of loading to a negligible amount through the use of a probe.

Use of Probes

Occasionally connecting the input of an oscilloscope to a signal source loads the source sufficiently to adversely affect both the operation of the source and the waveform displayed on the oscilloscope. In such cases an attenuator

probe may be used to decrease both the capacitive and resistive loading caused by the oscilloscope to a negligible value.

In addition to providing isolation of the oscilloscope from the signal source, an attenuator probe also decreases the amplitude of the displayed waveform by the attenuation factor of the probe. Use of the probe allows you to increase the vertical-deflection factors of the oscilloscope to observe large-amplitude signals beyond the normal limits of the oscilloscope. Signal amplitudes, however, must be limited to the maximum allowable value of the probe used. When making amplitude measurements with an attenuator probe, be sure to multiply the observed amplitude by the attenuation of the probe.

If the waveform being displayed has rapidly rising or falling voltages, it is generally necessary to clip the probe ground lead to the chassis of the equipment being tested. Select a ground point near the point of measurement, as shown in Fig. 3-6.

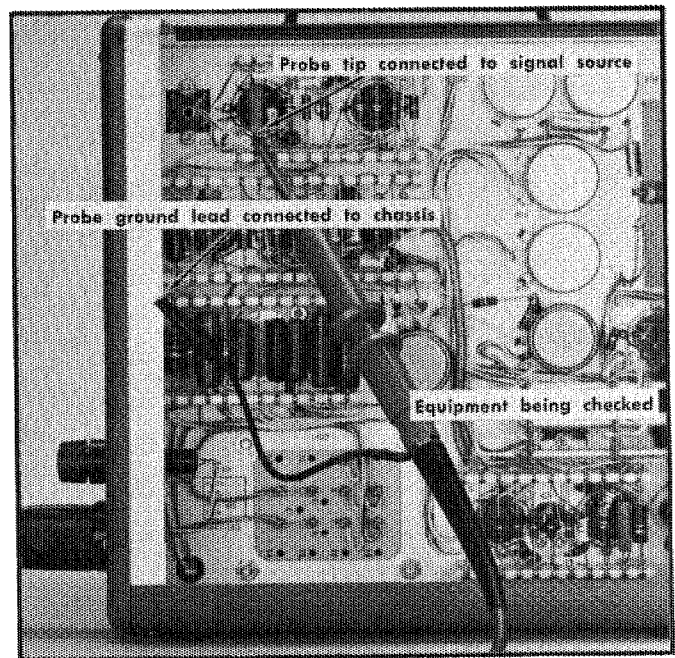

Fig. 3-6. Connecting a probe to the input signal source.

Before using a probe you must check (and adjust if necessary) the compensation of the probe to prevent distortion of the applied waveform. The probe is compensated by adjusting the control located in the body of the probe. Adjustment of the probe compensates for variations in input capacitance from one instrument to another. To insure the accuracy of pulse and transient measurements, this adjustment should be checked frequently.

To adjust the probe compensation, set the VOLTS/DIV control to the .01 position and the LEVEL control to the AUTO position. Set the SLOPE switch to + and the INT-EXT switch to INT. Connect the probe tip to the CAL OUT 500 MV connector. Set the TIME/DIV switch to .5 MILLI SEC and adjust the probe to obtain flat tops on the displayed square waveform (see Fig. 3-7.)

Voltage Measurements

The Type 321A Oscilloscope can be used to measure the voltage of the input waveform by using the calibrated vertical-deflection factors of the oscilloscope. The method used for all voltage measurements is basically the same although the actual techniques vary somewhat depending on the types of voltage measurements, i.e., ac-component voltage measurements, or instantaneous voltage measurements with respect to some reference potential. Many waveforms contain both ac and dc voltage components, and it is often necessary to measure one or both of these components.

When making voltage measurements, you should display the waveform over as large a vertical portion of the screen as possible for maximum accuracy. Also, it is important that you do not include the width of the trace in your measurements. You should consistently make all measurements from one side of the trace. If the bottom side of the trace is used for one reading, it should be used for all succeeding readings. The VARIABLE (VOLTS/DIV) control must be in the CALIB detent position.

Ac Component Voltage Measurements

To measure the ac component of a waveform, the AC-DC-GND switch should be set to the AC position. In this position only the ac components of the input waveform are displayed on the oscilloscope screen. However, when the ac component of the input waveform is very low in frequency, it will be necessary for you to make voltage measurements with the AC-DC-GND switch in the DC position.

To make a peak-to-peak voltage measurement on the ac component of a waveform, perform the following steps (see Fig. 3-8).

1. With the aid of the graticule, measure the vertical distance in divisions from the positive peak to the negative peak.
2. Multiply the setting of the VOLTS/DIV control by the distance measured to obtain the indicated voltage.
3. Multiply the indicated voltage by the attenuation factor of the probe you are using to obtain the true peak-to-peak voltage.

As an example of this method, assume that using the P6006 Probe and a deflection factor of 1 volt per division, you measure a vertical distance between peaks of 4 divisions. In this case, then, 4 divisions multiplied by 1 volt per division gives you an indicated voltage of 4 volts peak-to-peak. The indicated voltage multiplied by the probe's attenuation factor of 10 then gives you the true peak-to-peak amplitude of 40 volts.

When sinusoidal waveforms are measured, the peak-to-peak voltage obtained can be converted to peak, rms, or average voltage through use of standard conversion factors.

Instantaneous Voltage Measurements

The method used to measure instantaneous voltages is virtually identical to the method described previously for the measurement of the ac components of a waveform. However, for instantaneous voltage measurements the AC-DC-GND switch must be placed in the DC position. Also, since instantaneous voltages are measured with respect to some potential (usually ground), a reference line must be established on the oscilloscope screen which corresponds to that potential. If, for example, voltage measurements are to be made with respect to +100 volts, the reference line would correspond to +100 volts. In the following procedure a method is presented for establishing this reference line at ground, since measurements with respect to ground are the

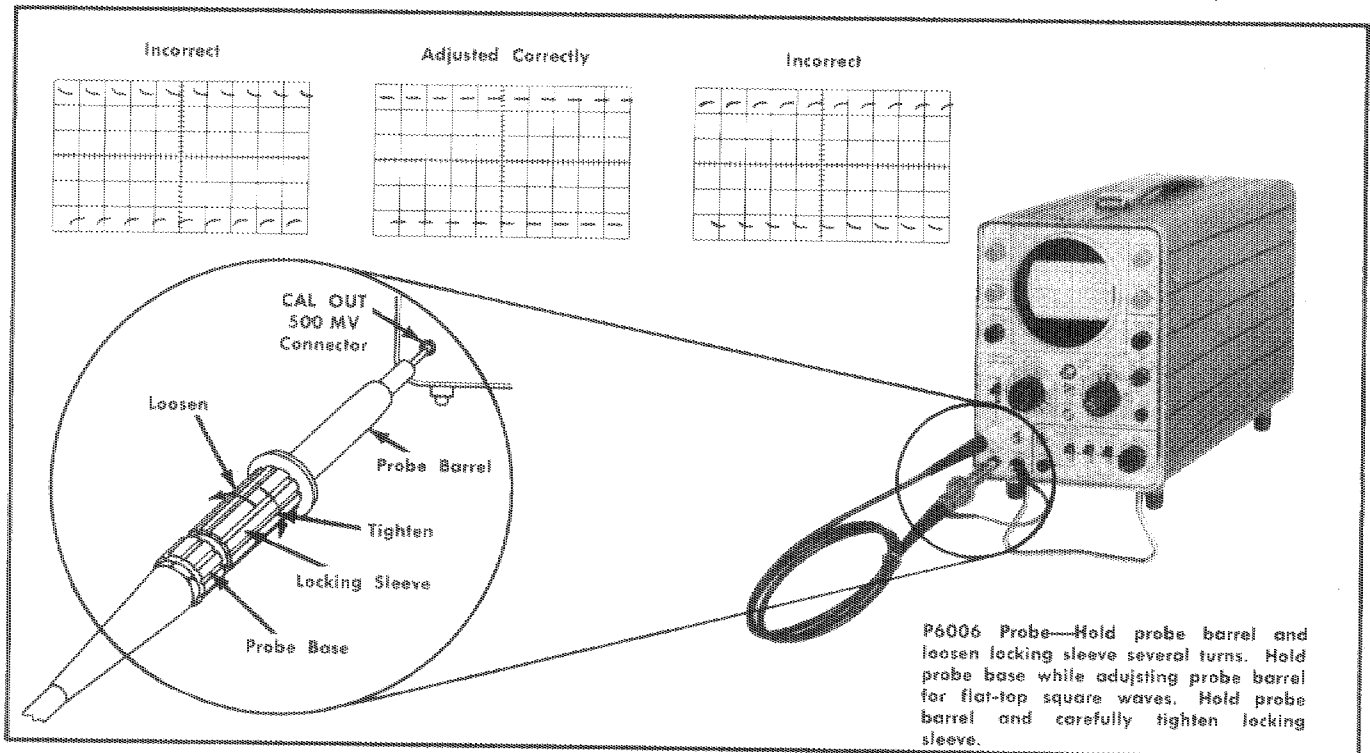

Fig. 3-7. The probe is adjusted to obtain an undistorted presentation of the calibrator squarewave.

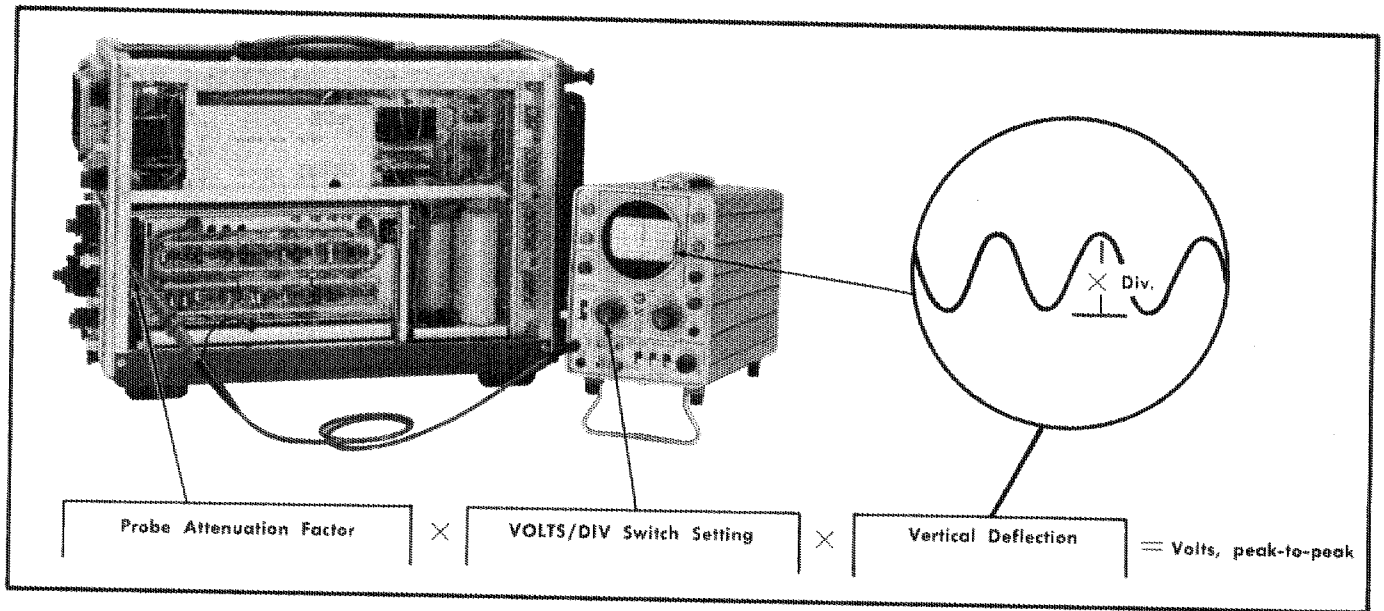

Fig. 3-8. Measuring the peak-to-peak ac voltage of an applied waveform.

most common type. The same general method may be used to measure voltage with respect to any other potential, however, so long as that potential is used to establish the reference line.

To obtain an instantaneous voltage measurement with respect to ground, or some other voltage, perform the following steps (see Fig. 3-9).

1. To establish a ground reference line, set the AC-DC-GND switch to GND. Or, to establish a reference line which represents a voltage other than ground, touch the probe tip to the voltage and leave the AC-DC-GND switch at DC. Then adjust the oscilloscope controls to obtain a free-running sweep. Vertically position the trace

to a convenient point on the oscilloscope screen. This point will depend on the polarity and amplitude of the input signal, but should always be chosen so that the trace lies along one of the major divisions of the graticule. The graticule division corresponding to the position of the trace is the voltage reference line and all voltage measurements must be made with respect to this line. (Do not adjust the VERTICAL POSITION control after the reference line has been established.)

2. If ground reference was established, set the AC-DC-GND switch to DC; if a reference line other than ground was established, remove the probe tip from this voltage and connect it to the signal source. Adjust the LEVEL control for a stable display.

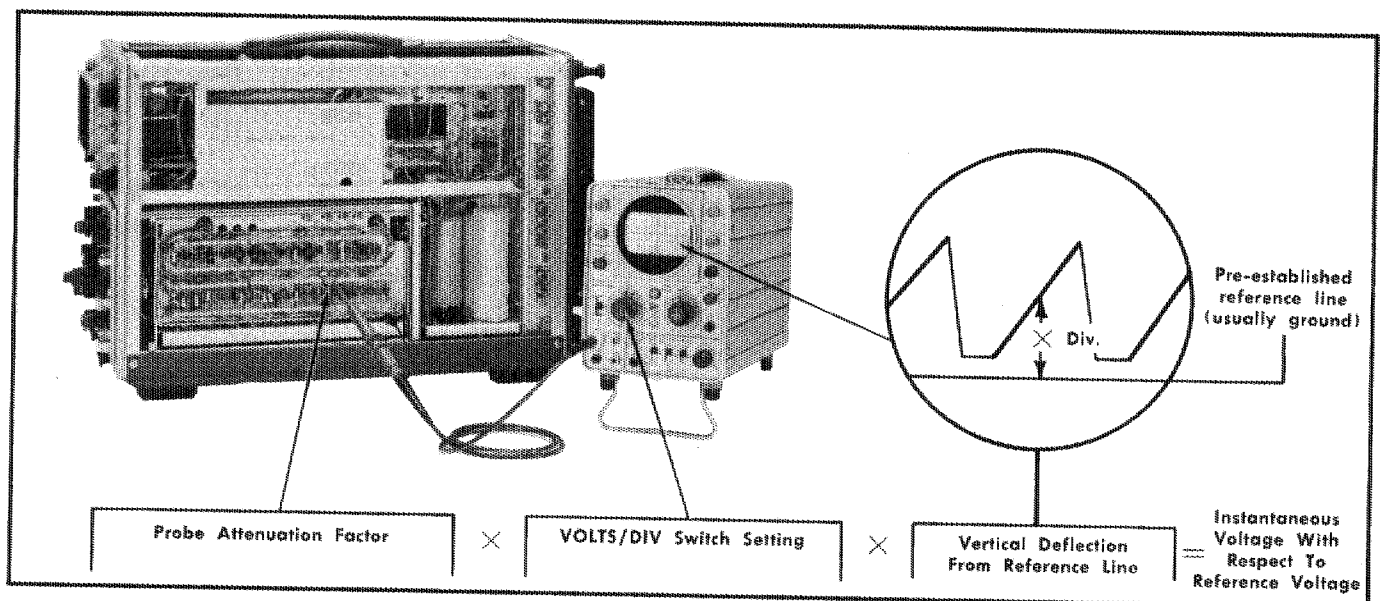

Fig. 3-9. Measuring the instantaneous voltage with respect to ground (or some other reference voltage).

Operating Instructions — Type 321A

3. Measure the vertical distance in divisions from the desired point on the waveform to the voltage reference line.
4. Multiply the setting of the VOLTS/DIV control by the distance measured to obtain the indicated voltage.
5. Multiply the indicated voltage by the attenuation factor of the probe you are using to obtain the actual voltage with respect to ground (or other reference voltage).

As an example of this method, assume you are using the P6006 Probe and a deflection factor of 0.2 volt per division. After setting the voltage reference line at the second from bottom division of the graticule, you measure a distance of 3 divisions to the point you wish to check. In this case, 3 divisions multiplied by 0.2 volt per division gives you an indicated 0.6 volt. Since the voltage point is above the voltage reference line the polarity is indicated to be positive. The indicated voltage multiplied by the probe attenuation factor of 10 then gives you the actual voltage of +6 volts.

Time Measurements

The calibrated sweep of the Type 321A Oscilloscope causes any horizontal distance on the screen to represent a definite known interval of time. Using this feature you can accurately measure the time lapse between two events displayed on the oscilloscope screen. One method which produces sufficient accuracy for most applications is as follows (see Fig. 3-10).

1. Measure the horizontal distance between the two displayed events whose time interval you wish to find.
2. Multiply the distance measured by the setting of the TIME/DIV control to obtain the apparent time interval. (The VARIABLE TIME/DIV control must be in the CALIB position.)

NOTE

Divide the apparent time interval by 5 if the magnifier is on.

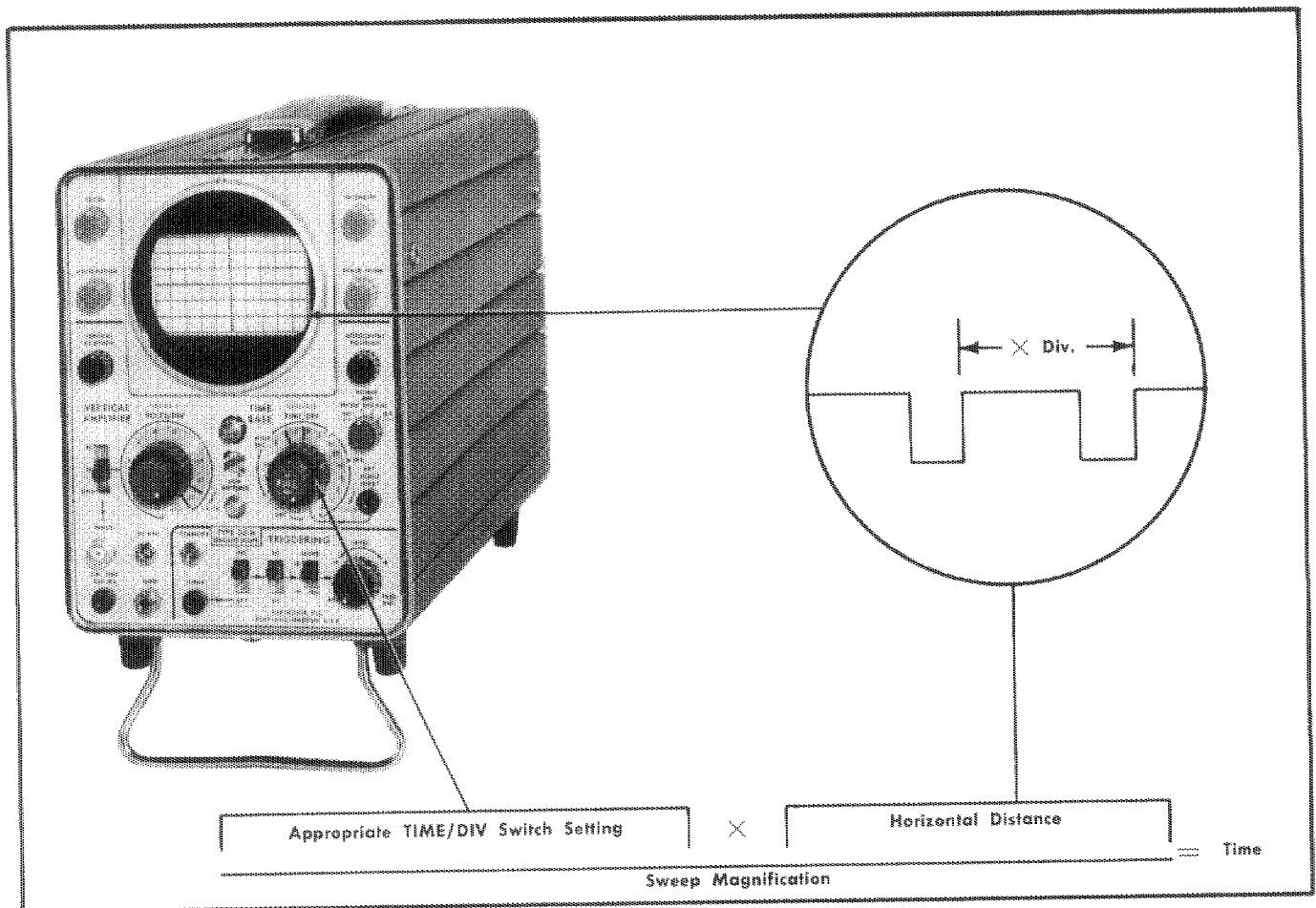

Fig. 3-10. Measuring the interval between events displayed on the oscilloscope screen.

For example, assume the TIME/DIV switch setting is 1 MILLI SEC, the magnifier is on, and you measure a horizontal distance of 5 division between events. In this example, then, 5 divisions multiplied by 1 millisecond per division gives you an apparent time interval of 5 milliseconds. The apparent time divided by 5 then gives you the actual time interval of 1 millisecond.

Frequency Measurements

The frequency of a periodically recurrent waveform can be determined if the time interval (period) of one complete cycle of the waveform is known. This time interval can be measured by means of the procedure described in the preceding paragraph. The frequency of a waveform is the reciprocal of its time interval, i.e., $f = 1/t$.

SECTION 4

CIRCUIT DESCRIPTION

Block Diagram

The block diagram in Section 7 of this manual shows the main sections of the Type 321A Oscilloscope. Waveforms to be displayed are connected to the Vertical Amplifier INPUT terminal, located on the front panel of the instrument. Large signals are attenuated the desired amount (up to 2000 times) in the attenuator networks. The signal is then amplified in the Vertical Amplifier and fed push-pull to the vertical deflection plates of the crt.

A trigger-pickoff circuit in the Vertical Amplifier applies a sample of the input signal to the Time-Base Trigger circuit. This sample signal is instrumental in starting the horizontal sweep. An external triggering signal connected to the Triggering INPUT terminal may also be used for this purpose.

Signals of widely varying shapes and amplitudes may be applied to the Time-Base Trigger circuit. This circuit in turn produces constant-amplitude output pulses which are used to start the horizontal sweep at the proper time to insure a stable display of the vertical-input waveform.

The output pulses from the Time-Base Trigger circuit are applied to the Time-Base Generator to initiate the sawtooth horizontal-sweep waveform. The sawtooth waveform is then amplified in the Horizontal Amplifier and applied push-pull to the horizontal deflection plates of the crt. For X-Y applications of the instrument an externally-generated signal can be applied to the EXT HORIZ INPUT terminal. The external signal is then amplified by the Horizontal Amplifier and applied to the horizontal deflection plates of the crt.

The gain of the Horizontal Amplifier can be increased five times by pulling the (Time Base) VARIABLE control outward to the 5X MAG position.

The Calibrator produces a square wave output of constant amplitude which can be used to check the gain of the Vertical Amplifier and compensate the probe. A 40-mv peak-to-peak square wave, is coupled internally to the Vertical Amplifier when the VOLTS/DIV switch is set to the CAL 4 DIV position. If the gain of the amplifier is properly adjusted, this will produce a deflection of exactly 4 divisions when the (Vertical Amplifier) VARIABLE control is set to the CALIB detent position. A square wave having a peak-to-peak amplitude of 500 mv is available at the CAL OUT terminal on the front panel of the instrument; this waveform can be used to compensate the probe.

The regulated power supplies in the Type 321A will operate from a 115-v or a 230-v rms ac line, from an external dc source (11.5 v to 35 v), or from a "battery pack" consisting of either 10 size D flashlight cells or 10 size D rechargeable cells. A built-in battery charger charges the "rechargeable" cells when the instrument is connected to an ac source (115 v or 230 v).

VERTICAL AMPLIFIER

Input Coupling

Input signals to the Vertical Amplifier can be either ac-coupled, dc-coupled, or internally disconnected. When

the AC-DC-GND switch SW401 (see Vertical Amplifier circuit diagram) is in the DC position, input signals are directly coupled to the VOLTS/DIV switch. In the AC position input signals are coupled through a blocking capacitor C401. In the GND position the signal path is opened and the input circuit is grounded.

Input Circuit

The Vertical Amplifier requires an input signal of 0.01 volt, peak-to-peak, to produce 1 division of calibrated deflection on the crt. To satisfy this condition, yet make the instrument applicable to a wide range of input voltages, a precision attenuation network is incorporated into the vertical deflection system.

When the VOLTS/DIV switch (SW410) is in the .01 position, the signal is coupled "straight through" (without attenuation) to the grid of V423. For all other settings of the VOLTS/DIV switch (except CAL 4 DIV) the Attenuators are switched into the input circuit, either singly or in tandem pairs, so that the input signal voltage to the Vertical Amplifier is always 0.01 volts for each division of crt deflection when the VARIABLE knob is in the CALIB detent position.

The Attenuators are frequency-compensated voltage dividers. For dc and low-frequency signals they are resistance dividers, and the degree of attenuation is determined by the resistance values. The impedance of the capacitors, at dc and low frequencies, is so high that their effect in the circuit is negligible. As the frequency of the input signals increases, however, the impedance of the capacitors decreases and their effect in the circuit becomes more pronounced. For high-frequency signals the impedance of the capacitors is so low, compared to the resistance in the circuit, that the Attenuators become capacitive reactance dividers.

In addition to providing the proper degree of attenuation, the resistance values in the Attenuators are chosen to provide the same input resistance (1 megohm) regardless of the setting of the VOLTS/DIV switch. Moreover, the variable capacitor at the input to each network provides a means for adjusting the input time constant so that it is the same value (nominally $35 \text{ pf} \times 1 \text{ meg}$) for all settings of the switch.

Input Cathode Follower

A nuvistor, V423, is used as a cathode-follower input stage. This stage presents a high-impedance, low-capacitance load to the input circuit and isolates the input circuit from the main amplifier. R422 is the 1-megohm input resistor. This resistor becomes a part of each attenuation network when the VOLTS/DIV switch is turned away from the .01 position. R423, bypassed by C423, prevents the grid of V423 from drawing excessive current (in the event the stage is overdriven) when dc input coupling is used. R424 is a parasitic suppressor.

Circuit Description — Type 321A

Input Emitter Follower

An emitter-follower stage Q443 couples the Input C.F. to the Input Amplifier. The output impedance of Q443 is very nearly equal to the output impedance of V423 divided by the β of Q443. This stage thus provides the necessary low-impedance drive (approximately 20 Ω) for the base of Q464, one-half of the Input Amplifier stage. The opposite emitter-follower Q453 couples a dc voltage, adjustable by means of the DC BAL control, to the base of Q474 (the other half of the Input Amplifier stage). The purpose of this dc voltage will be discussed in the following section.

Input Amplifier

The Input Amplifier consists of Q464 and Q474 connected as an emitter-coupled paraphase amplifier. In addition to amplifying the signal, this stage converts the single-ended input at the base of Q464 to a push-pull output signal between the two collector circuits. Q474 operates essentially as a grounded-base amplifier (grounded through the low output impedance of Q453); the input signal to Q474 is developed across the impedance in its emitter circuit.

There are two gain controls located in the common emitter circuit of the Input Amplifier. One is the front-panel VARIABLE control R478; the other is the VERT GAIN R468, an internal screwdriver-adjust potentiometer. Both controls vary the emitter degeneration and thus affect the gain of the stage. The VERT GAIN control is adjusted so that the amount of crt deflection agrees with the setting of the VOLTS/DIV switch when the VARIABLE control is turned to the CALIB detent position.

The DC BAL control R432 is used to adjust the dc level of Q474 so that its emitter will be at the same voltage as the emitter of Q464 when no input signal is applied to the instrument. With the emitters at the same voltage there will be no current through the VARIABLE control. With this configuration an adjustment of the VARIABLE control will not affect the dc level in the collector circuit of the Input Amplifier and will therefore not affect the positioning of the beam.

Vertical Positioning

The VERTICAL POSITION control is a dual control, connected between -10 and $+10$ volts. It is connected electrically so that as the voltage at one arm changes in the direction toward -10 volts the voltage at the other arm changes in the positive direction. This causes the voltage at the emitter of Q464 to change in the opposite direction to the voltage at the emitter of Q474. The change in emitter voltages in the Input Amplifier stage Q464/Q474 will be reflected as a change in deflection voltage at the crt, since direct coupling is employed between these two points.

Second Amplifier

The Second Amplifier stage Q484/Q494 provides a high-impedance, low-capacitance load for the Input Amplifier, and provides a low-impedance drive for the base of the Output Amplifier.

Output Amplifier

The Output Amplifier Q504/Q514 is a conventional collector-loaded, push-pull amplifier to drive the vertical deflec-

tion plates of the crt. A transistor, Q519, sets the emitter current for Q504 and Q514. There are two time-constant networks connected between the two emitters.

One network consists of diodes D505 and D506, connected back to back across R505 in series with R504. This network reduces the emitter-to-emitter impedance when the trace is positioned to the top or bottom of the graticule. Thus the gain of the stage is increased at the upper and lower deflection limits to offset crt compression. As a result, the displayed waveform will not change in amplitude regardless of trace location.

The other network consists of R506, C506, C507, and C508. This is an extremely short time-constant network (a fraction of a microsecond) and affects only fast-rise signals. The capacitive branches of this network offer less degeneration at high frequencies and thus improve the high-frequency response of the stage. The amount of high-frequency compensation can be adjusted by means of variable capacitor C506.

The dc level of the Output Amplifier is established, in part, by the divider in the base circuit of the Second Amplifier (R479 and R482 on one side and R489 and R492 on the other). These dividers help set dc level of Q504 and Q514 so that the maximum swing in collector voltage can be obtained.

TRIGGERING

Time-Base Trigger

The Time-Base Trigger circuit consists of a Trigger Input Amplifier stage Q14/Q24 and a rectangular-pulse Trigger Multivibrator Q35/Q45. The main function of the trigger circuitry is to produce a positive-going rectangular pulse at the collector of Q45 whose repetition rate is the same as that of the triggering signal. The positive step is then differentiated to produce a very sharp positive spike (trigger) which is used to trigger or start the sweep.

Triggering Signals

The triggering-input signal, from which the rectangular output is produced, may be obtained from an external source through the (Triggering) INPUT terminal, or it may be obtained from the Vertical Amplifier. When the INT-EXT switch SW2 is in the EXT position, the input circuit is arranged to receive external signals. In the INT position, the signal is received internally from the Vertical Amplifier. A Trigger-Pickoff stage Q524 (shown on the Vertical Amplifier diagram) receives a sample of the vertical-output signal from the collector circuit of Q514. The signal at the emitter of Q524, which is in phase with the vertical input signal at the grid of V423, is then coupled to the Time-Base Trigger circuit.

When the AC-DC switch SW8 is in the AC position trigger input signals are ac-coupled through C8; in the DC position C8 is bypassed with a direct connection.

Trigger Multivibrator

When the (Triggering) LEVEL control is set between AUTO and FREE RUN for triggered operation, the Trigger Multivi-

brator Q35/Q45 is a bistable Schmitt Circuit. It is forced from one of its stable states into the other by the triggering signal applied to the base of Q35. In the first stable state (ready to receive a signal) Q35 is cut off and its collector voltage is up (near ground). This holds up the base of Q45, since the two circuits are dc-coupled, and Q45 conducts. With Q45 conducting its collector voltage is down; hence no output is being produced.

A positive-going signal is required at the base of Q35 to force the multivibrator into its second stable state to produce the positive step at the collector of Q45. However, since the signal at the base of Q35 is an amplification of the triggering signal, it contains both positive- and negative-going portions.

The positive-going portion of the triggering signal will drive the base of Q35 in the positive direction. When the base voltage is just out of cutoff, Q35 starts conducting and its emitter voltage will rise, following the base. This pulls up the emitter of Q45, since the two emitters are strapped together.

At the same time the collector voltage of Q35 starts to drop, carrying with it the base voltage of Q45. With the base of Q45 down and its emitter up, Q45 cuts off. As Q45 cuts off its collector voltage rises, creating a positive step at the output. This transition occurs very rapidly, regardless of how slowly the base signal of Q35 may rise.

When the signal at the base of Q35 starts in the negative direction just the opposite chain of events occurs. Q35 cuts off and its collector voltage rises. This pulls the base of Q45 out of cutoff and Q45 conducts. As Q45 conducts its collector voltage drops; this completes the positive step-voltage output from the Trigger Multivibrator circuit.

Trigger-Input Amplifier

Although the output of the Trigger Multivibrator is always a positive step voltage, the start of the step may be initiated by either the rising (positive-going) or falling (negative-going) portion of the triggering signal. The amplified triggering signal is always taken from the collector of Q24, but the base of either transistor (Q14 or Q24) can be connected to the input circuit. When the SLOPE switch SW15 is in the + position the base of Q14 is connected to the input circuit and the base of Q24 is connected to a bias source adjustable by means of the LEVEL control. With this configuration Q14/Q24 is a differential amplifier and the signal at the collector of Q24 is in phase with the signal at the base of Q14. A positive-going signal at the input will therefore produce a positive-going signal at the base of Q35 and, as explained previously, this is the action that initiates the sweep. The sweep will therefore start on the positive slope (rising portion) of the triggering signal when the SLOPE switch is in the + position.

When it is desired to trigger the sweep on the falling or negative-going portion of the triggering signal, the signal at the base of Q35 must be opposite in polarity to the signal at the input circuit. This is accomplished by placing the SLOPE switch in the — position. With this arrangement the base of Q24 is connected to the input circuit and the base of Q14 is connected to the bias source. The configuration is still a differential amplifier and gain is the same as before, but the output signal is now opposite in polarity to the base signal.

Triggering Level

The setting of the (Triggering) LEVEL control determines the point (instantaneous voltage) on the triggering signal at which the sweep is started. This is accomplished as follows:

The quiescent state of the Trigger-Input Amplifier is such that the collector voltage of Q24 is about in the center of the hysteresis of the multivibrator. An adjustment of the LEVEL control will vary the bias on the transistor to which it is connected. This in turn will vary the dc level at the collector of Q24 to within the hysteresis range of the multivibrator. By adjusting the LEVEL control, the operator can select the point on the waveform at which he wishes to trigger the sweep.

Automatic Triggering

The sweep can be triggered automatically, instead of manually, by turning the LEVEL control full left to the AUTO position. In the AUTO position SW17 is opened, which alters the circuit configuration as follows: (a) the switch end of R38 is disconnected from the —10-volt decoupled supply to provide feedback from the collector of Q45 to its base; (b) the LEVEL control R17 is disconnected from the circuit; and (c) all triggering-input signals are ac-coupled through C8 regardless of the setting of the AC-DC switch.

In the automatic (AUTO) triggering mode, the Trigger Multivibrator is converted from a bistable configuration to a recurrent (free-running) configuration. (This is not to be confused with FREE RUN position of the LEVEL control; in the latter position the Time-Base Generator free runs).

The charging and discharging action of C30, fed to the base of Q45 and driving it, sets the Trigger Multivibrator recurrent rate at about 50 cps when no signal or low-amplitude signal is applied to the base of Q35. When a signal of sufficient amplitude to overcome the hysteresis of Q35 is applied, then the repetition rate of the applied signal (if it is higher than 50 cps) takes over and controls the switching rate of the multivibrator circuit.

Assume no signal is applied to the base of Q35 for example. Also, assume that Q35 has just turned off and Q45 has turned on. Under these conditions, for the first half cycle (duration is about 10 msec), C30 is charging to the voltage set by divider R33, R34, and the collector of Q45. As C30 charges, it is driving Q45 base toward cut off. Q35 emitter, through direct coupling to the emitter of Q45, is moving in a direction which will eventually turn Q35 on; the base of Q35 meanwhile is set at a fixed level by Q24 collector. After about 10-msec charging time, C30 cuts off Q45 and Q35 turns on.

Now, for the next half cycle C30 is discharging toward the voltage set by divider resistors R32, R43, R33, and R34. As C30 is discharging, C30 is driving Q45 toward its forward bias point. After about 10 msec discharging time, C30 discharges sufficiently to drive Q45 into conduction and C35 cuts off. This completes one cycle of the 50-cps output of the multivibrator.

As mentioned earlier, when a signal of sufficient amplitude is applied to the base of Q35 and the repetition rate of the signal is higher than 50 cps, the signal drives the

Circuit Description — Type 321A

base of Q35 and controls the switching rate of the Trigger Multivibrator. Capacitor C30 under these conditions has negligible effect on controlling the multivibrator action.

With this configuration just described, the sweep can be triggered with repetitive signals, over a wide range of frequencies, without readjustment. When no signal is applied to the base of Q35, the sweep continues at approximately a 50-cycle rate because the Trigger Multivibrator provides the trigger signal which triggers the Time-Base Generator. Thus, the sweep generates a base line which indicates that the instrument is ready to display any signal (within the voltage and frequency limits of the instrument) that might be connected to the vertical deflection system.

SWEEP GENERATION

Time-Base Generator

The positive-going pulses produced by the Time-Base Trigger circuit are differentiated in the base circuit of Q135. The sharp positive spikes produced by the differentiation process are used to start the sweep; the negative spikes are not used.

The Time-Base Generator consists of three main circuits . . . a bistable Sweep-Gating Multivibrator, a Miller Integrator Circuit, and a Hold-Off Circuit. Transistors Q135 and Q145 make up the Sweep-Gating Multivibrator. In the stable state immediately following a sweep Q135 is nonconducting and Q145 is conducting.

The essential components in the Miller Circuit are the Miller transistors Q161 and Q163, the emitter-follower Q173, the gating transistor Q153, the "disconnect" diode D153, the Timing Capacitor C160, and the Timing Resistor R160. The Hold-Off Circuit consists mainly of the emitter-follower Q183 and the Hold-Off Capacitors C180 and C181.

In the quiescent state the gating transistor Q153 is held in conduction (by the conducting multivibrator transistor Q145) and its emitter voltage is negative. This holds the cathode of D153 negative and forces the diode to conduct. In this state the low forward impedance of Q153 and D153 shunts the Timing Capacitor and prevents it from charging. This action also clamps the Miller Circuit in such a way that the emitter-followers Q163 and Q173 conduct very little and the amplifier Q161 conducts heavily.

Sweep Generation

The next positive trigger to arrive at the base of Q135 will force the Sweep-Gating Multivibrator into its second stable state in which Q145 is cut off. The rise in voltage at the collector of Q145 pulls up the base of Q153 and this stage cuts off. The rise in voltage at the emitter of Q153 then back-biases D153 and the diode stops conducting. This action unclamps the Miller Circuit and permits it to seek its own voltages.

The base of Q163 then starts positive, since it is connected through the Timing Resistor to the +45-volt bus (when the VARIABLE control is in the CALIB position). The emitter of Q163 and the base of Q161 also start positive, following the base of Q163. The collector of Q161 then starts negative, carrying with it the base and emitter of Q173. This causes the voltage at the lower side of the Timing Capacitor to

increase in the negative direction which in turn pulls down the base of Q163 and prevents it from going positive. The gain of the Miller Circuit is such that the feedback network maintains the voltage at the base of Q163 virtually constant (within about one-tenth of a volt).

The Timing Capacitor then start charging with current through the Timing Resistor and the emitter-follower Q173. Since the voltage at the base of Q163 remains essentially constant, the voltage across the Timing Resistor, and hence the charging current through it, remains essentially constant. The Timing Capacitor therefore charges linearly, and the voltage at the emitter of Q173 increases linearly (in the negative direction). Any departure from a linear increase in the voltage at this point will produce a change in the voltage at the base of Q163 in a direction to correct for the error.

The linear increase in voltage at the emitter of Q173 is used as the sweep time base. Timing Capacitor C160 and Timing Resistor R160 are selected by the setting of the TIME/DIV switch SW160. The Timing Resistor determines the current that charges the Timing Capacitor. By means of the TIME/DIV switch, both the size of the capacitor being charged and the charging current can be selected to cover a wide range of sweep speeds. The setting of the TIME/DIV switch therefore determines the speed at which the spot moves across the crt.

If uncalibrated sweep rates are desired the VARIABLE control R160V can be turned away from the CALIB position. This connects the Timing Resistor to a voltage adjustable between +45 v and +10 v, which varies the sweep rate over about a 4 to 1 range.

Retrace

The length of the sweep—the distance the spot moves across the crt—is determined by the setting of the SWP LENGTH control R176. As the sweep voltage increases negatively at the emitter of Q173 there will be a linear increase in voltage at the arm of R176 and at the base of Q183. This will pull down the voltage at the emitter of Q183 and at the base of Q135. When the voltage at the base of Q135 falls to cutoff, the Sweep-Gating Multivibrator will rapidly revert to its original state with Q135 cut off and Q145 conducting. The voltage at the collector of Q145 will then drop, carrying with it the base of Q153. This will gate on Q153 and the diode D153 and provide a discharge path for C160.

The resistance through which C160 discharges (R153 and the forward resistance of Q153 and D153) is much less than that through which it charges (R160, R178, and the forward resistance of Q173). The capacitor current during discharge will therefore be much larger than during charge, and the Miller transistors will return rapidly to their quiescent state. This produces the retrace portion of the sweep sawtooth, during which time the crt beam returns rapidly to its starting point.

Hold-Off

The Hold-Off Circuit prevents the Time-Base Generator from being triggered during the retrace interval. In addition, the hold-off allows a finite time for the sweep circuits to regain a state of equilibrium after the completion of a sweep.

During the trace portion of the sweep sawtooth the Hold-Off Capacitors C180-C181 charge through Q183 as a result of the drop in voltage at the emitter of Q183. This pulls the base of Q135 negative until Q135 cuts off. As explained previously, this is the action that initiates the retrace.

At the start of the retrace C180 and C181 start discharging through R181. The time-constant of this circuit is such that during the retrace, and for a short period after the completion of the retrace, the base of Q135 is held far enough below cutoff that positive triggers cannot switch the Sweep-Gating Multivibrator. When the Hold-Off Capacitors have discharge to a predetermined voltage (established by the setting of the STABILITY control) the effect of the hold-off is removed. This returns the Sweep-Gating Multivibrator to its quiescent state in which it can be triggered by the next positive trigger to arrive at the base of Q135.

Stability Control

The STABILITY control R111 regulates the dc level at the base of Q135 within the hysteresis of the Sweep-Gating Multivibrator. When this control is properly adjusted, the base of Q135 is held just negative enough that Q135 is back-biased and nonconducting; this prevents the circuit from free running. The base voltage must be sufficiently close to cutoff so that positive triggers can pull Q135 out of cutoff and force the multivibrator into its other state to initiate the sweep.

During the trace portion of the sweep sawtooth, when the Hold-Off Capacitors are charging, the emitter of Q183 is forced negative. When the emitter of Q183 is more negative than the arm of the STABILITY control diode D111 is back biased; this disconnects the STABILITY control from the Multivibrator circuit.

During the retrace portion of the sweep sawtooth the Hold-Off Capacitors discharge. When the voltage at the emitter of Q183 rises to the voltage at the arm of the STABILITY control diode D111 conducts and clamps the Hold-Off Circuit at this voltage. With the base of Q135 clamped in this manner, a sweep can only be produced when a positive trigger pulls Q135 out of cutoff.

However, should a free-running trace be desired, the (Triggering) LEVEL control can be turned full right to the FREE RUN position. This opens switch SW17 and forces the arm of the STABILITY control to ground potential. This permits the base of Q135 to rise to cutoff immediately upon removal of the hold-off voltage, at which point the next sweep is initiated.

Unblanking

The crt in the Type 321A contains a second set of horizontal deflection plates (pins 6 and 10; see diagram for Crt Circuit). Pin 10 is connected to +10 volts; pin 6 is connected to the Unblanking Amplifier (shown on the Time-Base Generator diagram). In the interval between sweeps, pin 6 rests at about -20 volts; the crt beam is therefore deflected off the screen and is not visible.

When a positive trigger switches the Sweep Gating Multivibrator to start a sweep, the negative gate at the collector of Q135 is coupled to the base of Q194. This results in a 30-volt positive gate at the collector of Q194,

which in turn is fed to pin 6 of the crt. The 30-volt positive gate, whose start and duration are coincident with the start and duration of the sweep, pulls pin 6 of the crt up to +10 volts, the same as pin 10. This deflects the crt beam back into the range of visibility for the trace portion of the sweep sawtooth.

Transistor Q199 is connected as a load-stabilizer. Q199 conducts when Q194 is nonconducting. When Q194 conducts, during sweep time, Q199 is nonconducting. This circuit prevents the switching of Q194 from changing the load on the power supply, and therefore prevents crosstalk to the Vertical Amplifier.

HORIZONTAL AMPLIFIER

Input Circuit

The Horizontal Amplifier consists of an emitter-follower input stage Q313 and an emitter-coupled paraphase amplifier Q334/Q344. For all sweep-time settings of the TIME/DIV switch, the negative-going sweep sawtooth produced by the Miller Circuit is coupled to the Input E.F. Q313 via the frequency-compensated voltage divider R311-R312. In the EXT HORIZ INPUT setting of the switch, Q313 receives its signal from the EXT HORIZ INPUT connector. This setting of the switch also produces the following results: (1) The Time-Base Generator is rendered inoperative; (2) The emitter of Q194 (Unblanking circuit) is clamped at about +10 volts, thus removing the blanking potential at pin 6 of the crt.

Emitter-follower Q323 balances the Horizontal Amplifier for dc potentials. This stage also couples the positioning voltage from the HORIZONTAL POSITION control R321 to the amplifier circuit.

Output Amplifier

Q334 and Q344 are connected as an emitter-coupled paraphase amplifier to provide the push-pull drive for the horizontal deflection plates of the crt. The setting of the HORIZ GAIN control R338 determines the emitter degeneration and thus sets the gain of the stage. A second gain control R348 (MAG GAIN) is connected in the emitter circuit when the VARIABLE timing control is pulled out to close SW348. This action decreases the degeneration and increases the gain 5 times to provide 5X sweep magnification.

REGULATOR CIRCUIT

Power Sources

The function of the Regulator circuit in the Type 321A is to provide a regulated 10 volts dc for the converter-type power supply. The Regulator is designed to operate from a self-contained battery pack, from an external 11.5-v to 35-v dc source, or from either a 115-v or a 230-v rms, 50-800 cycle ac line.

To operate from the internal batteries only, the POWER switch SW621 is set to BATT ON. The POWER switch connects the internal batteries directly to the Regulator circuit via TK621 and F621. TK621 is a thermal cutout switch that opens if the ambient temperature of the Type 321A

Circuit Description — Type 321A

rises to about 131° F ($\pm 5^\circ$) and closes when the chassis temperature drops to 120° F ($\pm 8^\circ$). Normally, for internal battery mode of operation other voltage sources are not connected to the Type 321A at this time.

Operation from an external dc source is accomplished by connecting the special pigtail-type dc power cord in the proper manner. For 11.5- to 20-v operation, the black (+) and white (—) leads are connected to the voltage source; for 20- and 35-v operation, the green (+) and white (—) leads are connected to the source. The ac line cord is not used during this mode of operation. To turn on the Type 321A the POWER switch is set to EXT ON. The switch connects the dc source to the regulator circuit. Diode D620 is normally back-biased to keep T601 disconnected since the T601 secondary portion of the circuit is not used at this time.

For ac line operation the ac power cord is connected to the ac line and line power is applied through F601 to the T601 primary winding. The primary of power transformer T601 has split input windings; these may be connected in parallel for operation from a 103.5-126.5 volt line, or in series for a 207-253 volt line.

Graticule lights and an ac rectifier are connected to the secondary windings of T601. The ac rectifier is a conventional full-wave type, with a capacitor-input filter. When the POWER switch is set to EXT ON, the output of the ac rectifier is applied through D620, the POWER switch, TR621 and F621 to the Regulator circuit. At nominal line voltages the ac rectifier provides a voltage of about 14.5 volts across C696.

Voltage Regulation

The Regulator circuit is designed to respond both to changes in supply voltage and to changes in loading. Reference voltage for the Regulator circuit is furnished by Zener diode D629. This diode provides a constant dc voltage of about +5.1 volts (with respect to the common negative bus) at the base of Q624, one-half of a difference amplifier. The base voltage for the other half of the difference amplifier, Q634, is obtained from a divider R650, R651, and R652. The 10 V ADJ control R651 determines the percentage of total voltage that appears at the base of Q634 and thus determines the total voltage across the divider. This control is adjusted so that the output is exactly 10 volts.

The regulation of the output, in the presence of line-voltage or load changes, is accomplished by varying the impedance of Q657 in a direction to compensate for the change. For example, assume the output voltage tends to decrease. This will lower the base voltage of Q634 and alter the current distribution through the difference amplifier. That is, the current through Q634 will decrease and the current through Q624 will increase.

The resultant drop in voltage at the collector of Q624 will pull down the base and emitter of Q654. This action drives the base of Q657 toward its collector, which increases the current through Q657 and lowers its impedance.

The unregulated voltage is equal to the output voltage plus the drop across Q657. The decrease in impedance of Q657 lowers its emitter-to-collector voltage, which causes the output voltage to increase to its proper value.

If the output voltage tends to increase, just the opposite will occur. The base voltage of Q634 will increase, more current will flow through Q634 and less current will flow through Q624. The rise in voltage at the collector of Q624 will pull up the base and emitter of Q654, and the base of Q657. This decreases the current through Q657 and increases its impedance.

As the impedance of Q657 increases its voltage drop increases. This in turn lowers the output voltage to its proper value.

Battery Charger

When the Type 321A is connected to a source of ac power and the POWER switch is turned to TRICKLE or FULL, the rectified output of T601 is sufficient to cause a back current through the 12-volt battery, resulting in a charging of the cells (if rechargeable cells are used). The resistive network of R692, R693, and the internal resistance of the cells determine the amount of charging current which will flow. When the POWER switch is set to FULL and the Charger switch is in the LOW position, 200 ma will flow through the battery at nominal line voltage. When the Charging switch is in the HIGH position, 360 ma will flow through the battery. When the Charger switch is in the DRY CELLS position, the circuit is opened up and no current will flow.

When the POWER switch is turned to TRICKLE, R694 is inserted in series with R692 and/or R693 and the current is limited to about 40 ma, just enough to maintain the existing charge on the cells.

Low-Batteries Light

Transistor Q614 and associated circuitry constitute the low-batteries warning-light system. The emitter of Q614 is held constant by the 10-volt regulated supply, the base is controlled by a voltage dividing network consisting of R695, R696, and R697. The network connects across the unregulated supply voltage. The LOW BATTERIES B699] light is connected in the collector circuit of Q614.

Under normal conditions when the internal batteries provide a voltage of more than 11.5 volts (± 0.2 v), transistor Q614 is cut off and the LOW BATTERIES light is off. However, if the unregulated voltage drops to about 11.5 volts or less due to low batteries, Q614 base-emitter junction forward biases and Q614 conducts, thus turning on the light.

As a secondary function of this circuitry, the LOW BATTERIES light acts as a warning light for either of these conditions: (1) If the Type 321A is operated from a low external ac line source or (2) from a low external dc source. If either condition causes the unregulated voltage to fall to about 11.5 volts, or lower, Q614 will conduct and turn on the LOW BATTERIES light.

Diode D614 is a protection diode for Q614. Normally the diode is forward-biased to limit the reverse-bias voltage across the base-emitter junction of Q614 during cut off. When the unregulated voltage drops to about 11.5 volts or lower, D614 reverse biases and Q614 base-emitter junction becomes forward-biased to turn on the light.

CONVERTER

The regulated 10 volts output of the Regulator circuit is applied to the Converter transistors Q700-Q710. Both transistors are biased in the forward direction when power is applied, but because of slight difference in characteristics one will start conducting before the other. Current flowing in the collector circuit of the conducting transistor will then induce a voltage into the base windings (terminals 5, 6, and 7) of transformer T701. The polarity of the base voltages induced will be such that the conducting transistor will conduct more, and the nonconducting transistor will be driven into cutoff.

The buildup of current in the conducting transistor will continue until the transformer saturates. At saturation the induced voltage in the base windings will start decaying and the conducting transistor will accordingly conduct less. The collapsing field will then induce voltages of the opposite polarity in the base windings. This will drive the transistor that had been conducting into cutoff, and turn on the transistor that had previously been cut off. The circuit will then produce a secondary voltage of the opposite polarity. The repetition rate of the circuit is about 2 kc.

The transistor current, flowing in the primary circuit of T701, is somewhat trapezoidal in shape; the secondary voltage is therefore nearly a square wave. A full-wave rectifier with capacitor-input filters provides dc output voltages of -47.5 , -45 , -10 , $+5.8$, $+10$, and $+45$ volts. An additional half-wave rectifier circuit provides -720 volts for the crt gun.

An ac signal of approximately 100 volts, peak-to-peak, is coupled from terminal 10 of T701 to the Calibrator circuit (shown on the Vertical Amplifier and Calibrator diagram). The 100-volt ac signal square wave is clipped in Q874 and divided down to provide the 500-millivolt external signal available at the CAL OUT 500 MV terminal, and the 40-millivolt square wave internally coupled to the Vertical Amplifier in the CAL 4 DIV position of the VOLTS/DIV switch.

CRT CIRCUIT

Crt Control Circuits

The INTENSITY control R844, part of a divider connected between -720 volts and ground, varies the crt grid-to-cathode voltage to regulate the beam current. The FOCUS control R842 varies the voltage at the focusing anode to set the second cross-over point right at the crt screen. The ASTIGMATISM control R864 varies the voltage at the astigmatism anode to focus the spot in both dimensions simultaneously. The GEOM ADJ R861 varies the field the beam encounters as it emerges from the deflection system to control the linearity at the extremes of deflection.

High Voltage Supply

A pentupler, starting with the voltage at Terminal 16 of T701, builds up a potential of 3350 volts for the post-deflection accelerator in the crt. This provides an accelerating potential of approximately 4 KV, since the cathode voltage is about -670 volts.

SECTION 5

MAINTENANCE

PREVENTIVE MAINTENANCE

Recalibration

The Type 321A Oscilloscope is a stable instrument and will provide many hours of trouble-free operation. To insure the reliability of measurements obtained on the Type 321A however, we suggest its calibration be checked after each 500 hours of operation, or at least every six months if used intermittently. A check of the calibration also provides a means for checking the operation of each circuit. Minor operational deficiencies that are not apparent in normal use are often detected during a calibration check.

A complete step by step procedure for checking the calibration of the instrument is included in Section 6 of this manual.

Soldering Precautions

In the production of Tektronix instruments a special silver-bearing solder is used to establish a bond to the ceramic terminal strips. This bond may be broken by repeated use of ordinary tin-lead solder, or by excessive heating of the terminal strip with a soldering iron. However, occasional use of ordinary solder will not break the bond if too much heat is not applied.

In those shops responsible for the maintenance of several Tektronix instruments it is advisable to have a stock of solder containing about 3% silver. This type of solder is used frequently in printed-circuit work and is generally available. Or it can be purchased from Tektronix in one-pound rolls; order by part number 251-514.

REMOVAL AND REPLACEMENT OF PARTS

General Information

Procedures required for replacement of most parts in the Type 321A Oscilloscope are obvious. Detailed instructions for their removal are therefore not required. Other parts, however, can best be removed if a definite procedure is followed. Instructions for removal of some of these parts are contained in the following paragraphs. Because of the nature of the instrument, replacement of certain parts will require that you recalibrate portions of the oscilloscope to insure proper operation (refer to the Calibration procedure portion of this manual).

Removal of Panels

The panels of the Type 321A Oscilloscope are held in place by small screwhead fasteners. To remove the side panels, use a screwdriver to rotate the fasteners approximately two turns counterclockwise; then pull the upper portion of the panel outward from the carrying handles. Panels are replaced by reversing the order of their removal.

To remove the battery cover, loosen the thumb screw at the front of the cover and pull the front end out for a short distance. Then slide the cover forward to clear the clips at the rear end (see Fig. 2-3 in Section 2).

Replacement of the Cathode-Ray Tube

To remove the crt, first disconnect the tube socket and all leads connected to the neck of the tube. Loosen the tube clamp at the base of the crt and remove the graticule cover and graticule. (Remove the graticule cover by removing the phillips head screw located on the lower part of the cover.) Pull the crt straight out through the front panel. When the new crt is in place, the leads can be properly connected to the neck of the tube by following the color code information provided on the tube shield. After replacement of the crt, it will be necessary to check the calibration of the oscilloscope.

Replacement of Switches

Methods for removal of defective switches are, for the most part, obvious and only a normal amount of care is required. Single wafers are normally not replaced on the switches. If one wafer is defective the entire switch should be replaced. Switches can be ordered from Tektronix either wired or unwired, as desired.

Replacement of Ceramic Terminal Strips

To remove a ceramic terminal strip, unsolder all components and connections, then pry the strip with studs attached out of the chassis. An alternative method is to use diagonal cutters to cut off one side of each stud to free the strip. Try not to damage the spacer. After removing the strip, the remainder of each stud can be easily extracted from the chassis with a pair of pliers. The studs need not be salvaged since new ones are furnished with the new strips. If the spacers are not damaged, they can be reused as long as they hold the strip assembly securely.

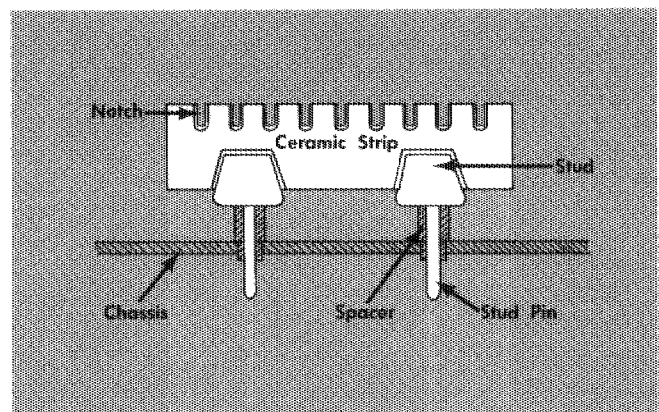

Fig. 5-1. Installation of a ceramic strip.

1. Regulator Circuit
2. Converter Circuit
3. Crt Circuit and High-Voltage Supply
4. Vertical Amplifier
5. Time-Base Trigger Circuit
6. Time-Base Generator
7. Horizontal Amplifier

The first circuit to check, for practically any type of trouble, is the 10-Volt Regulator circuit. An improper output voltage from this supply will affect the operation of the entire instrument.

In some cases an improper voltage from the Converter may affect one circuit more than the others. In these cases, valuable time can be saved by checking the supply voltages first.

On the other hand, the crt display can often be used to isolate trouble to one particular circuit when trouble obviously exists in that circuit. If there is no vertical deflection, for example, when the intensity and horizontal deflection appear to be normal, it is apparent that an open condition exists in the Vertical Amplifier and this circuit should be investigated first.

The material that follows contains information for troubleshooting each circuit for troubles that may be caused by a defect in the circuit. A method is described, in some instances, for locating the stage in which the trouble may be originating; once the stage at fault is known, the components causing the trouble can be located by voltage and resistance measurements or by substitution. In certain other instances the information is more specific and the trouble can be traced to a particular component.

Circuit failure may be caused by transistor failure. If replacement of a defective transistor does not correct the trouble, then check the components associated with the transistors.

TROUBLESHOOTING THE REGULATOR CIRCUIT

Proper operation of every circuit in the Type 321A depends on proper operation of the Regulator circuit and the Converter. The dc voltages must remain within their specified tolerances for the instrument to retain its calibration.

Open Power Circuit (Dead Circuit)

With the AC 115V (or 230V) line connected, an increase in the SCALE ILLUM control (cw) should brighten the graticule lights. If the graticule lights do not come on, check the source of power, power connection, and the fuse F601.

NOTE

Disconnect the power cord when working on the transformer T601 or associated circuits. If the fuse is blown, replace it with one of the proper value and reconnect the ac line cord. If the new fuse blows immediately, check the power transformer for shorted primary or secondary windings. Shorted rectifiers in the secondary circuit will also blow the fuse F601. Check for an open primary winding in the power transformer if the fuse is good.

Incorrect Voltage

With the POWER switch in the EXT ON position, you should measure exactly 10 volts across C657; (see Fig. 6-1, Section 6). If this voltage is not present, check for an open fuse F621 or thermal cutout switch TK621. (Resistance of the thermal cutout switch is about 0.1 Ω). If the fuse is blown, replace it with one of the proper value and turn the instrument on again. If the new fuse blows immediately, disconnect either the Converter circuit or the Crt circuit, or both, from the Regulator circuit to isolate the trouble (see Fig. 5-2). If the fuse continues to blow, the trouble lies in the Regulator circuit. If the Regulator circuit is free of trouble connect, one at a time, the Converter and the Crt circuit to locate the source of trouble. Once the circuit at fault is known, you can then troubleshoot within this circuit

TABLE 5-1
Typical Resistances

Test Point	Location (Fig. No.)	Type of Meter: 20,000 Ω /v VOM		Type of Meter: Mfr: Model No.: Type 321A Ser. No.:	
		Resistance Readings*	Ohms Range Used	Resistance Readings	Ohms Range Used
+45 v	6-2	200 Ω , 6k	RX1K		
+10 v	6-2	1300 Ω , 560 Ω	RX100		
+5.8 v	6-2	2.5 Ω , 12 Ω	RX1		
-10 v	6-2	1.4k, 450 Ω	RX1K		
-45 v	6-2	6k, 1.6k	RX1K		
-720 v	6-2	4.5 Meg, 22k	RX100K		
**Battery Term.		9.6 Ω , 40 Ω	RX1		

*Reverse the ohmmeter leads to get both readings.

**Measured across the internal battery terminals located at the bottom rear portion of the instrument.

to locate the defective component(s). The Circuit Description (see Section 4) of the circuit involved may prove useful when troubleshooting within a given circuit.

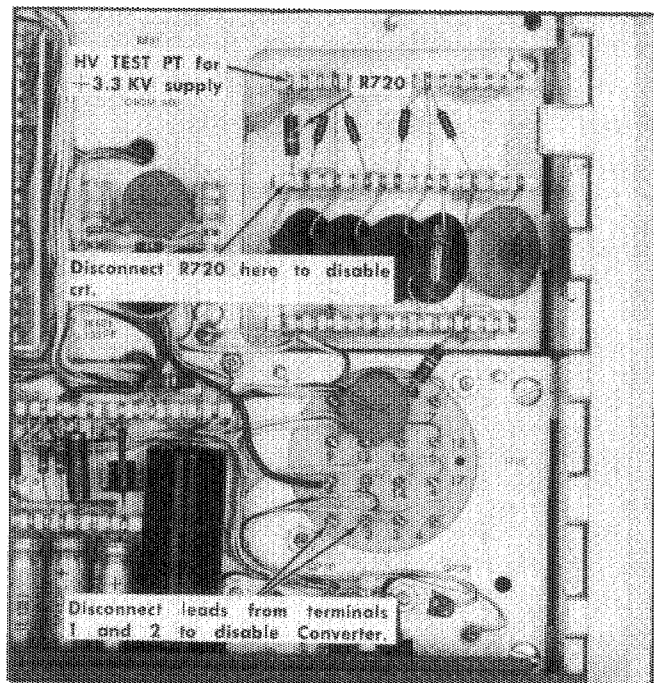

Fig. 5-2. Troubleshooting the Regulator circuit (rear right-side view).

If varying the line voltage between 103.5 and 126.5 volts (or 207 and 253 volts for 230-v operation) varies the output of the 10-Volt Regulated supply, check for defective transistors in the Regulator circuit. Transistors Q700 and Q710 in the Converter circuit may also affect the regulation of the 10-Volt Regulated supply.

TROUBLESHOOTING THE CONVERTER

The Converter voltages depend upon the operation of Q700 and Q710. These are the converter transistors and failure to operate will result in zero output.

Test points for checking the converter voltages are located on the right side of the oscilloscope (see Fig. 6-2 in Section 6). If the converter transistors, Q700 and Q710, are inoperative, check to see if the regulated 10 volts is being applied across the converter transistors. Also check for shorted primary or secondary windings (T710). A short in any rectifier circuit will also cause the converter to be inoperative. If an improper voltage reading is obtained at any of the indicated points, check the 10V ADJ control R651 for correct setting.

TROUBLESHOOTING THE CRT CIRCUIT

The intensity, focus, geometry, and calibration of the crt display depend on proper operation of the -720-volt supply and the high-voltage supply in the crt circuit. The -720 volts is dependent upon the converter for proper operation. For trouble in this supply refer to the converter troubleshooting procedure.

No Intensity

If the low-voltage power supply is operating normally, but no spot or trace is visible on the crt, the trouble could be a defective crt, a defect in the crt circuit including the -720-volt supply, an unbalanced condition in either or both of the deflection amplifiers, a defect in the Time-Base Generator circuit, or a defective unblanking circuit (to produce a spot or trace on the screen the crt must be unblanked).

To determine which circuit is at fault, turn the INTENSITY control full right. Set the LEVEL control to FREE RUN and the TIME/DIV control to 1 MILLI SEC. Short the vertical deflection plates together (at the neck pins on the crt) with a screwdriver. Be extremely careful not to short either pin to the metal shield around the crt. Adjust the HORIZONTAL POSITION control and see if a spot or trace appears on the crt. If so, a state of unbalance in the vertical deflection system is indicated. (Refer to Troubleshooting the Vertical Amplifier.)

If a spot or trace does not appear with the vertical deflection plates shorted, turn the instrument off and remove the leads that connect to the horizontal deflection plates. (Make sure that the metal clip on the end of each lead does not touch the chassis.) Turn the instrument back on and (after warmup) adjust the VERTICAL POSITION control. If a spot now appears on the crt, the Horizontal Amplifier is causing the trouble. If a spot does not appear, turn the instrument off and reconnect the leads to the horizontal deflection plates. Then turn the instrument back on and set the TIME/DIV switch to the EXT HORIZ INPUT position. If a spot now appears on the crt, after warmup (it may be necessary to adjust VERTICAL POSITION control), the Time-Base Generator is the circuit at fault. Refer to the appropriate troubleshooting section for trouble in either of these circuits.

If none of the previous checks indicates the source of the trouble, a defective crt or trouble in the high-voltage circuit is indicated. Measurement of the high voltage can be made at the top end of R720 (see Fig. 5-2). The voltage at this HV TEST PT should be approximately +3050 volts (when measured with a 20,000 Ω/v VOM). If the voltage is present, a defective crt is indicated. Also a defective rectifier D714, D715, D717, D718, or D719, will cause the high voltage to be inoperative.

TROUBLESHOOTING THE VERTICAL AMPLIFIER

No Spot or Trace Visible on Crt

If all power-supply voltages are normal, and the crt is known to be good, failure to obtain a spot or trace on the screen will be due to the Time-Base Generator and unblanking circuit or to improper positioning voltages. The latter conditions is caused by a dc unbalance in either or both of the deflection amplifier circuits.

To determine which circuit is at fault refer to "Troubleshooting the Crt Circuit" for the procedure to check the balance of the vertical and horizontal amplifiers.

If it is determined that the vertical deflection circuit is unbalanced, the next step is to check each stage for unbalance. Fig. 5-3 is a simplified diagram of the Vertical Am-

plifier showing test points for checking the balance of the amplifier. For this check it is convenient to have a short lead (about 8 to 10 inches) with a rubber-covered alligator clip on each end, and a voltmeter (5000 Ω per volt or better).

Connect the voltmeter between the base of Q504 and the base of Q514, and set the VERTICAL POSITION control to mid-position. A reading of less than 0.06 volt would indicate unbalance in the output stage (Q504, Q514). Check for defective transistors and associated circuit parts. A reading of 0.06 volt or more on the voltmeter indicates unbalance ahead (toward the input stage) of the voltmeter. Reconnect the voltmeter between the base of Q484 and Q494. A reading of less than 0.02 volt indicates unbalance in that stage. A reading of more than 0.02 volt indicates unbalance toward the input stage.

The next step is to connect together the collector of Q464 and the collector of Q474 with the shorting strap. If the trace appears on the crt (it may be necessary to adjust the VERTICAL POSITION control) the trouble lies either in one of the transistors or in some component ahead of this stage. From this point it is advisable to troubleshoot by substitution. Do not connect other points on opposite sides of the circuit together, as an improper voltage on one side could damage transistors on the other.

Insufficient or No Vertical Deflection

Insufficient vertical deflection indicates a change in the gain characteristics of the Vertical Amplifier. If there is only a slight deficiency in the deflection, as will usually be the case, the amplifier can generally be recalibrated for gain.

Refer to Section 6 for this. However, if the amplifier cannot be recalibrated, or if the decrease in gain is more pronounced, it will be necessary to check the transistors, tube, and circuit components.

If there is no vertical deflection on the crt, an inoperative condition in the vertical deflection system is indicated. If the trace can be moved with the VERTICAL POSITION control, the trouble is originating ahead of the control in one of the input stages of the Vertical Amplifier (input c.f., input e.f.).

If the trace cannot be moved with the VERTICAL POSITION control, one of the stages following the control is inoperative. In either of the above cases the tube or transistor should first be replaced, then circuit components should be checked.

TROUBLESHOOTING THE HORIZONTAL AMPLIFIER

No Spot or Trace on the Crt

To determine that the Horizontal Amplifier is in a state of dc unbalance, turn the instrument off and remove the leads that connect to the horizontal deflection plates. (Make sure that the metal clips on the end of each lead do not touch the chassis.) Turn the instrument back on and (after warmup), adjust the VERTICAL POSITION control. If a spot now appears on the crt, the trouble lies in either the Horizontal Amplifier or the Time-Base Generator. To determine which circuit is at fault, reconnect the leads to the hori-

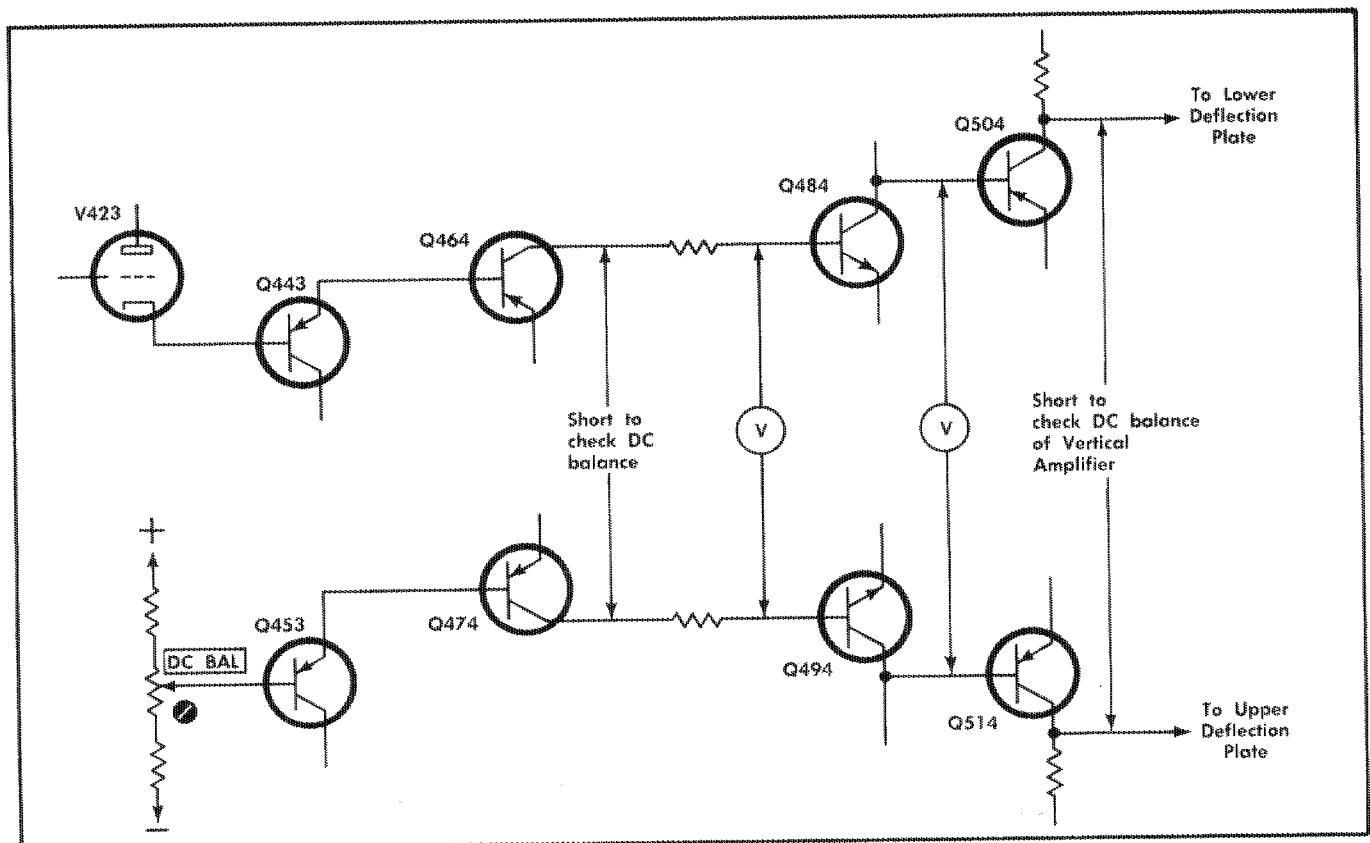

Fig. 5-3. Simplified diagram of the Vertical Amplifier showing test points for checking the dc balance of the amplifier.

zontal deflection plates and turn the TIME/DIV control to EXT HORIZ INPUT position. If the spot now appears, the Horizontal Amplifier is in balance and the trouble is being caused by an inoperative condition in the Time-Base Generator (refer to Troubleshooting the Time-Base Generator).

If no spot appeared on the crt with the TIME/DIV control in the EXT HORIZ INPUT position, the Horizontal Amplifier is causing the trouble. The procedure for troubleshooting the Horizontal Amplifier to locate the defective stage, is similar to that explained for troubleshooting the Vertical Amplifier for unbalance. A voltmeter (5000 Ω per volt or better) is used to determine which stage is unbalanced. Fig. 5-4 is a simplified diagram of the Horizontal Amplifier showing test points for checking the balance of the amplifier. Connect the voltmeter between the base of Q334 and the base of Q344. Set the HORIZONTAL POSITION control to mid-position. A reading of 1.5 volts or over will indicate an unbalance in the first stage (Q313, Q323). A reading of less than 1.5 volts will indicate an unbalance condition in the output stage (Q334, Q344). When the stage at fault is determined, check for defective transistors and components associated with that stage.

Insufficient or No Horizontal Deflection

If the gain of the Horizontal Amplifier decreases, the trace will not extend from the left to the right side of the graticule. In addition, the timing will no longer correspond to the calibrated value indicated by the TIME/DIV switch.

If the change is slight, as indicated by improper timing and a slightly decreased sweep, the amplifier can usually be recalibrated. Since the gain of the Horizontal Amplifier regulates the timing of the sweep, care must be taken to insure that the gain adjustments are accurately made. Be sure to refer to Section 6 if it is necessary to adjust the gain of the Horizontal Amplifier.

If there is no horizontal deflection on the crt the circuit at fault could be the Horizontal Amplifier or the Time-Base Generator.

The operation of the Time-Base Generator can be checked by measuring the voltage at the emitter of Q173. Set the

TIME/DIV control to .1 SEC and the LEVEL control to FREE RUN. Connect a voltmeter between the emitter of Q173 (see Fig. 5-5) and ground. If the voltage varies between zero and —20 volts, as the Miller Circuit runs down and back, the Time-Base Generator is operating properly and the trouble lies in the Horizontal Amplifier.

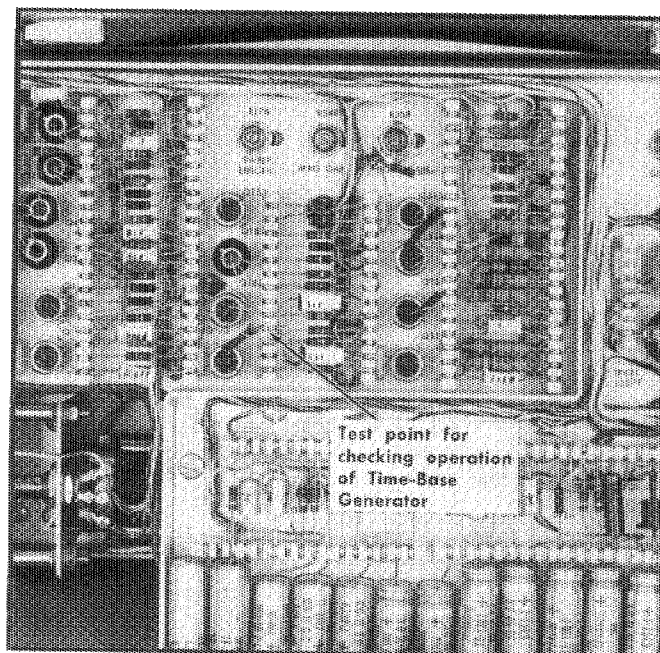

Fig. 5-5. Checking the operation of the Time-Base Generator by measuring the voltage at the emitter of Q173 (upper right-side view).

When the trouble has been isolated to either the Time-Base Generator (refer to troubleshooting the Time-Base Generator or the Horizontal Amplifier, a check of the transistors and circuit components should be made.

If there is some horizontal deflection on the crt, but not enough to cover the ten-division length of the graticule, the

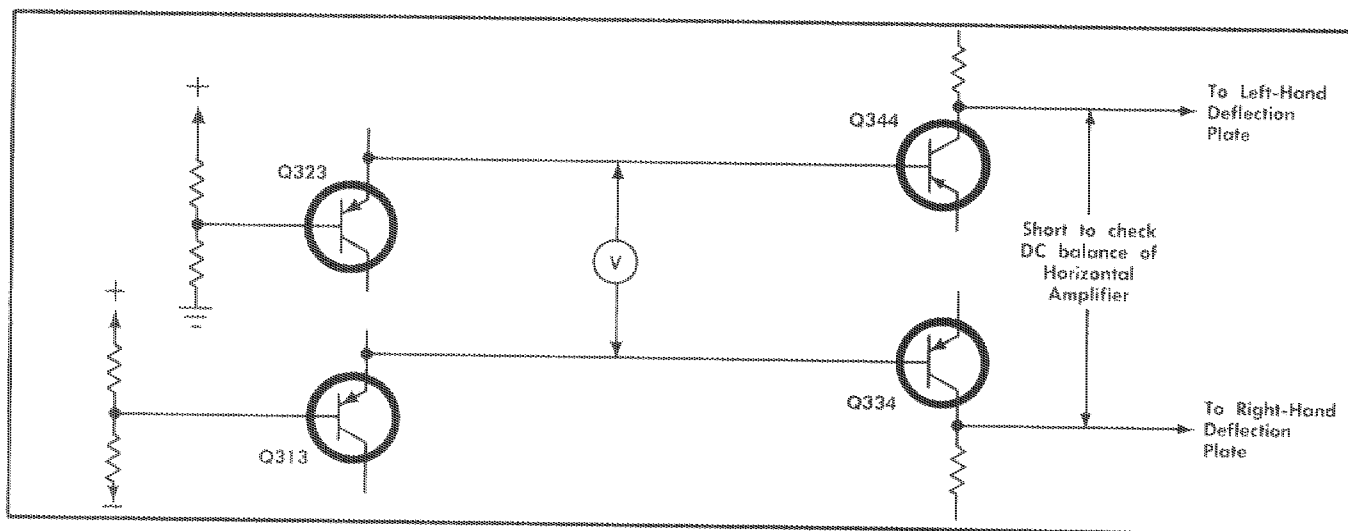

Fig. 5-4. Simplified diagram of the Horizontal Amplifier showing test points for checking the dc balance of the amplifier. TIME/DIV switch is set to EXT.

trouble either be due to insufficient output from the Time-Base Generator, or to insufficient gain in the Horizontal Amplifier.

The Time-Base Generator can be checked in the same manner as described previously. That is, by measuring for a 20-volt variation at the emitter of Q173, at a slow sweep rate. If this reading is not obtained, the Time-Base Generator is at fault, and its circuitry can be investigated. The SWP LENGTH control (R176) is very important and its setting should be checked first. For the proper adjustment of this control, refer to Section 6.

If the voltmeter indicates the proper reading (see Fig. 5-5) the Horizontal Amplifier will be the circuit at fault. Check for defective transistors and circuit components.

TROUBLESHOOTING THE TIME-BASE TRIGGER

Improper Triggering

If the waveform you are observing cannot be triggered (locked into position) properly, the trouble can be: (1) misadjustment of the STABILITY control, (2) the trigger pickoff circuit (trigger amplifier Q524) in the Vertical Amplifier, (3) Time-Base Generator, or (4) the Time-Base Trigger circuit.

Refer to Section 6 for misadjustment of the STABILITY control. The operation of the trigger pickoff circuit can be checked as follows: connect an external triggering signal (preferably the signal input waveform) to the (Triggering) INPUT connector. Set the INT-EXT switch to the EXT position. Check to see if the waveform can now be triggered. If so, the trigger pickoff stage Q524 is at fault; it is not passing the internal signal that develops the triggering pulse.

If the waveform cannot be triggered in either the INT or EXT position, some circuit in the Time-Base Trigger or the Time-Base Generator is not operating properly.

If the sweep can be turned off and on with the LEVEL control, the sweep generator is capable of being triggered. This indicates the Time-Base Trigger is not functioning properly. Check for defective transistors and circuit components.

TROUBLESHOOTING THE TIME-BASE GENERATOR

No Horizontal Sweep

It is important that you understand the operation of the Time-Base Generator before proceeding with any extensive investigation of the circuit. For this reason we suggest that you thoroughly study that portion of the Circuit Description pertaining to this circuit.

If the Time-Base Generator is not producing a sawtooth sweep when the LEVEL control is in the FREE RUN position, some defect is rendering the circuit inoperative. The timing components (R160-C160) and the hold-off capacitor (C180)

can be checked by rotating the TIME/DIV switch through its range. If a trace appears in some positions of the switch, the trouble will lie in the components associated with the inoperative position(s) of the switch.

If no trace appears in any position of the TIME/DIV switch, the generator is "hung up" either at the low end or at the high end of the sweep. Set the TIME/DIV switch to .5 MILLI SEC and measure the voltage at the emitter of Q173. If this voltage is very close to zero, the circuit is hung up at low end of the sawtooth; that is, the sweep cannot get started. In this case, voltage reading at key points in the circuit may help to isolate the source of trouble. Connect a voltmeter to the base of Q135 and turn the LEVEL control just slightly to the left, away from the FREE RUN position. Then vary the setting of the STABILITY potentiometer. The voltage at the base of Q135 should vary between about -3.5 volts and about -7.5 volts. Voltages outside of this range indicate trouble in the stability-control circuit . . . R111, R131, D111, D131. Also, check transistors Q135 and Q183; check D183 and R181 in the emitter circuit of Q183.

The operation of the Sweep-Gating Multivibrator can be checked by connecting the voltmeter to the collector of Q145 or base of Q153 and varying the setting of the STABILITY potentiometer. If no trouble exists in the multivibrator circuit, it will be forced from one stable state to the other as the STABILITY control is varied from one end of its range to the other. This will cause the collector voltage of Q145 to vary from about -1.1 to +1.6 volts. The base voltage of Q153 will vary from about -0.6 to +2 volts. Normal operation of the gating transistor Q153 is indicated by a voltage change at its emitter equal to about -0.32 to +0.6 volt.

If the voltage range at emitter of Q153 appears to be normal, the hang-up is occurring in the Miller circuit. A check of the voltages, at the points indicated on the circuit diagram, may indicate the source of the trouble. If not, check by substitution transistors Q161, Q163, and Q173, and Diode D153.

If the voltage at the emitter of Q173 is from -20 to about -40 volts, the circuit is hung up at the high (most negative) end of the sawtooth. This indicates that the discharge path of the Timing Capacitor C160 is blocked. Since the Timing Capacitor discharges through Q153, R153, and D153, these components should be checked first. Then check the action of the Sweep-Gating Multivibrator by the method mentioned previously. If the multivibrator is locked up so that Q145 is conducting, Q153 will be back-biased and will block the discharge path.

Improper Triggering

If the sweep cannot be triggered properly, the gating pulse from the Multivibrator (Q134-Q145) is not turning the diode D153 off and on properly. The start of the gating pulse, which turns the diode off and starts the sweep, is initiated by the triggering pulse at the base of Q135. The end of the gating pulse, which turns the diode on and initiates the retrace, is controlled by the hold-off waveform at the base of Q135. The main component to check, in addition to the transistors, is the differentiating capacitor C131.

TROUBLESHOOTING THE CALIBRATOR

Insufficient or No Calibrator Output

The Converter circuit supplies the signal to the Calibrator circuit. To check the Calibrator, turn the VOLTS/DIV control to the CAL 4 DIV position. Set the LEVEL control to the AUTO

position. There should now be displayed on the crt 4 vertical divisions of calibrator signal. If not, and the Vertical Amplifier is known to be working, check for a defective transistor Q874 and associated circuit components. For adjustment of the CAL ADJ control refer to Section 6. The CAL ADJ control will compensate for slight changes in the calibrator output. If the change is more pronounced, the transistor Q874 should be checked.

SECTION 6

CALIBRATION

EQUIPMENT REQUIRED

The following equipment is required for a full recalibration of the Type 321A Oscilloscope.

1. Dc voltmeter (sensitivity at least 20,000 Ω/v) calibrated for an accuracy of at least 1% at 5.8, 10, 45, 720, and 3300 volts. Be sure the meter is accurate; few portable meters have comparable accuracy, particularly after a period of use.
2. Accurate rms-reading ac voltmeter, 0-150 volts (0-250 or 0-300 volts for 230-volt operation).
3. Variable autotransformer having a rating of at least 1 ampere.
4. Test oscilloscope with 1 \times and 10 \times probes, accurately calibrated for vertical gain at 5, 10, 20, 50, and 100 mv per division. Bandwidth: dc to about 100 kc or higher.
5. Type P6006 10 \times passive probe (Tektronix part number 010-127 BNC) for use with the Type 321A. As a useful accessory, include an adapter (Tektronix part number 013-056) which adapts probe tip to fit a BNC jack.
6. Square-wave generator, Tektronix Type 105 or equivalent. If a Tektronix Type 105 is not available, it will be necessary to substitute a generator with the following characteristics: Output frequencies of about 1 kc and 400 kc; risetime 13 nsec or faster into a 50-ohm (nominal) cable terminated at both ends; output voltage variable from 10 to 100 volts across an internal 600-ohm load.
7. Constant-amplitude signal generator, Tektronix Type 190A or 190B or equivalent. If a Tektronix Type 190A or 190B is not available, it will be necessary to substitute a generator that provides up to 5 volts signal output. The output must be adjustable (manually or automatically) for constant amplitude within a frequency range of 500 kc to 6 mc, including a reference frequency of about 50 kc.
8. Time-mark generator, Tektronix Type 180 or 180A or equivalent. Markers required at 500, 100, 50, 10, 5, and 1 msec, 500, 100, 50, 10, 5, and 1 μ sec. All outputs must have a time accuracy of at least 0.1%.
9. 50-ohm (nominal impedance) coaxial cable, 42 inches long with BNC plug connectors on each end, Tektronix part number 012-057.
10. 50-ohm termination with one BNC plug and one BNC jack connector fittings, Tektronix part number 011-049.
11. 50-ohm 10:1 attenuator with one BNC plug and one BNC jack connector fittings, Tektronix part number 011-059.
12. Connector adapter, single binding post fitted with a BNC plug. Binding post accepts banana plug. Tektronix part number 103-033.
13. Connector adapter with BNC jack and UHF plug connector fittings, accepts BNC plug and fits UHF jack. Tektronix part number 103-015.

14. Clip-lead adapter for the Type 190A or 190B to perform step 19. Choose connector type that fits attenuator unit of generator; either a UHF type (Tektronix part number 013-003) or a BNC type (Tektronix part number 013-076).

15. Patch cord, 6" long, with banana plug-and-jack combination at each end. Tektronix part number 012-024.

16. Miscellaneous Items (one each)

Small screwdriver with $\frac{1}{8}$ " wide bit.

Large screwdriver with a $\frac{1}{4}$ " wide bit.

Nut driver, $\frac{5}{16}$ ", to fit locking hex nut on 10V ADJ control.

Plastic rod, $\frac{1}{4}$ " diameter, about 6" long, with a chisel tip.

Jaco No. 125 insulated low-capacitance-type screwdriver with a $1\frac{1}{2}$ " long shank and $\frac{1}{8}$ " wide metal tip. Total length is about 5". Tektronix part number 003-000.

ADJUSTMENT PROCEDURE

Preliminary Instructions

Remove the side covers from the Type 321A. Set up the front-panel controls as follows:

INTENSITY	Full left (ccw)
HORIZONTAL POSITION	Midrange
POWER	EXT ON
TIME/DIV	1 MILLI SEC
VARIABLE (TIME/DIV)	CALIB (full right)
5 \times MAG	Knob pushed in
TRIGGERING	
LEVEL	Midrange
SLOPE	+
AC-DC	AC
INT-EXT	INT
VOLTS/DIV	.1
VARIABLE (VOLTS/DIV)	CALIB
AC-DC-GND	DC
VERTICAL POSITION	Midrange

NOTE

Controls not listed above are not pertinent to this portion of the procedure and may be left in any position. Adjustment of these controls will be made at the appropriate time in the following procedure.

Calibration — Type 321A

Connect the Type 321A and ac voltmeter to the auto-transformer, and turn on all equipment. Set the output of the autotransformer to the design center voltage for which your instrument is wired (115 or 230 v).

If the instrument fails to calibrate in any of the following steps, refer to the Troubleshooting Procedure portion of this manual for information concerning the circuit involved.

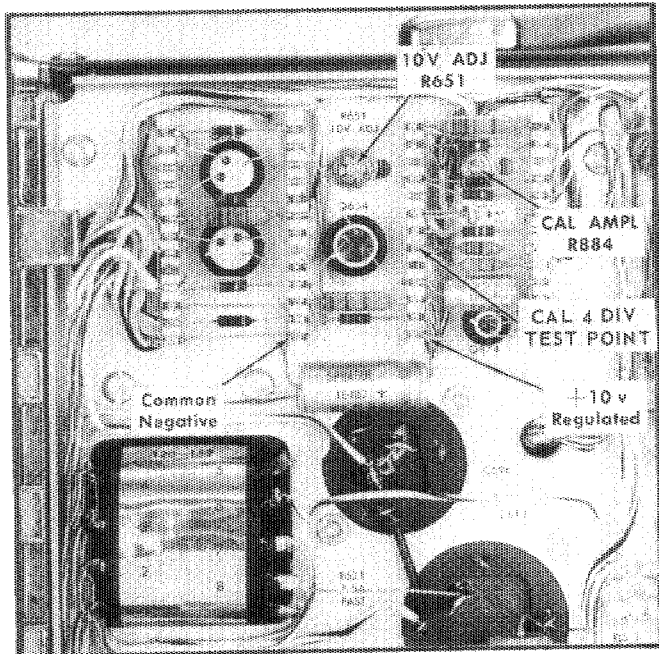

FIG. 6-1. Test point and adjustment locations for performing steps 1 and 3 (upper left side view).

1. Adjust 10-Volt Regulated Supply (Regulated Circuit)

- Connect a dc voltmeter across the 10-volt regulated supply at the points shown in Fig. 6-1.
- Adjust the 10V ADJ R651 control (see Fig. 6-1) for a reading of exactly 10 volts. Use a voltmeter known to be accurate.

NOTE

It will be necessary to loosen the lock nut before the 10V ADJ control can be adjusted. Set the

POWER switch to TRICKLE when loosening or tightening the lock nut.

- Check the regulation of the supply by slowly varying the output of the variable autotransformer between 103.5 and 126.5 volts (or 207 and 253 volts). These line-voltage ranges are equivalent to 10% below and above design-center voltage for which the Type 321A is wired. As the line voltage is varied, the 10-volt regulated supply should not vary any more than $\pm 0.5\%$ (± 50 mv).

NOTE

When checking for proper regulation of the power supplies at the lower line-voltage limit, the ac line voltage should contain no more than 1% sine-wave distortion.

- Reset the autotransformer to design-center line voltage.
- Disconnect the dc voltmeter.

2. Check Supply Voltage and Ripple of Other Supplies (Converter)

- Using Table 6-1 as a guide, check the supply voltage and output voltage ripple of each of the supplies listed. Refer to Fig. 6-2 for location of all test points except 3.3 kv which can be found by referring to Fig. 5-2 or Fig. 6-6. Use the dc voltmeter to check the supply voltages. Use the test oscilloscope with a $1\times$ probe to check ripple voltage.
- Disconnect the dc voltmeter and $1\times$ probe.

3. Adjust Calibrator Amplitude (Calibrator Circuit)

- Connect the test oscilloscope $1\times$ probe tip to the CAL OUT 500 MV connector. Connect the probe ground lead to the Type 321A GND connector.
- Set the test oscilloscope front-panel controls to obtain a stable display of several cycles of the waveform.
- Adjust the CAL AMPL R884 control (see Fig. 6-1) for exactly 500 mv peak-to-peak vertical deflection of

TABLE 6-1

Power Supply		Tolerance of Nominal Value	Maximum Peak-to-Peak Ripple
Name	Nominal*		
+45 V (dec)	+46.6 v	$\pm 2\%$	5 mv
+45 V	+45.0 v	$\pm 2\%$	10 mv
+10 V	+9.6 v	$\pm 2\%$	25 mv
+5.8 V	+5.8 v	$\pm 2\%$	125 mv
-10 V (dec #1)	-10.6 v	$\pm 2\%$	5 mv
-10 V	-10.6 v	$\pm 2\%$	5 mv
-10 V (dec #2)	-11.1 v	$\pm 2\%$	5 mv
-45 V	-44.9 v	$\pm 2\%$	20 mv
-47.5 V	-47.6 v	$\pm 2\%$	100 mv
-720 V	-730 v	$\pm 2\%$	2.0 v
+3.3 KV	+3400 v	$\pm 2\%$	Not checked

* Measured with a 20,000 Ω /v VOM.

the waveform displayed on the test oscilloscope. (Be sure the test oscilloscope itself is accurate.)

Disconnect the probe from the CAL OUT 500 MV connector.

- d. Connect the 1X probe to the CAL 4 DIV test point shown in Fig. 6-1. Adjust the test oscilloscope for stable display at a vertical deflection factor of 10 mv/cm. The amplitude at this point should be 40 mv, $\pm 3\%$.
- e. Disconnect the probe from the Type 321A.

4. Adjust Dc Balance (Vertical Amplifier)

- a. Rotate the LEVEL control fully clockwise to the FREE RUN position.
- b. Turn up the INTENSITY control until the trace is visible. Check that the VERTICAL POSITION control is set to midrange. Adjust the FOCUS, ASTIGMATISM and INTENSITY controls for a well defined trace of normal intensity.

NOTE

If the trace is not visible because it is above or below the crt viewing area, preadjust the DC BAL control (front-panel screwdriver adjustment) to position the trace near graticule center.

- c. Using the HORIZONTAL POSITION control, position the trace to start at the left edge of the graticule (0-cm graticule line).
- d. Rotate the VARIABLE (VOLTS/DIV) control slightly clockwise out of the detent CALIB position and back again. If any vertical displacement of the trace is apparent, adjust the DC BAL control until the trace remains stationary as the VARIABLE (VOLTS/DIV) control is rotated back and forth.
- e. Set the VARIABLE (VOLTS/DIV) control to the CALIB position.

5. Check Crt Alignment (Crt Circuit)

- a. Adjust the FOCUS and ASTIGMATISM controls for sharpest trace (narrowest trace width).
- b. Using the VERTICAL POSITION control, position the trace directly behind the center graticule line.
- c. If the trace and graticule line do not coincide over the length of the graticule, loosen the crt base clamp and rotate the crt.
- d. When the trace and graticule line are in coincidence, hold the bottom of the graticule cover in place so the crt does not dislodge it and push the crt forward using a plastic rod as a lever behind the crt socket. The crt face should rest snugly against the graticule.
- e. Recheck alignment of the trace but do not tighten the crt base clamp until after the next step.

6. Adjust Geometry (Crt Circuit)

- a. Using the VERTICAL POSITION control, position the trace to the top graticule line.
- b. If any curvature is present in the trace, adjust the GEOM ADJ R861 control for minimum curvature.
- c. Position the trace to the bottom graticule line and, if necessary, repeat the previous step.

NOTE

A compromise setting of the GEOM ADJ control may be necessary for best over-all linearity.

- d. Position the trace to graticule center and recheck alignment of the trace. If the trace and graticule line coincide, tighten the crt base clamp. If the trace does not coincide, rotate the crt slightly for proper coincidence and then tighten the base clamp.

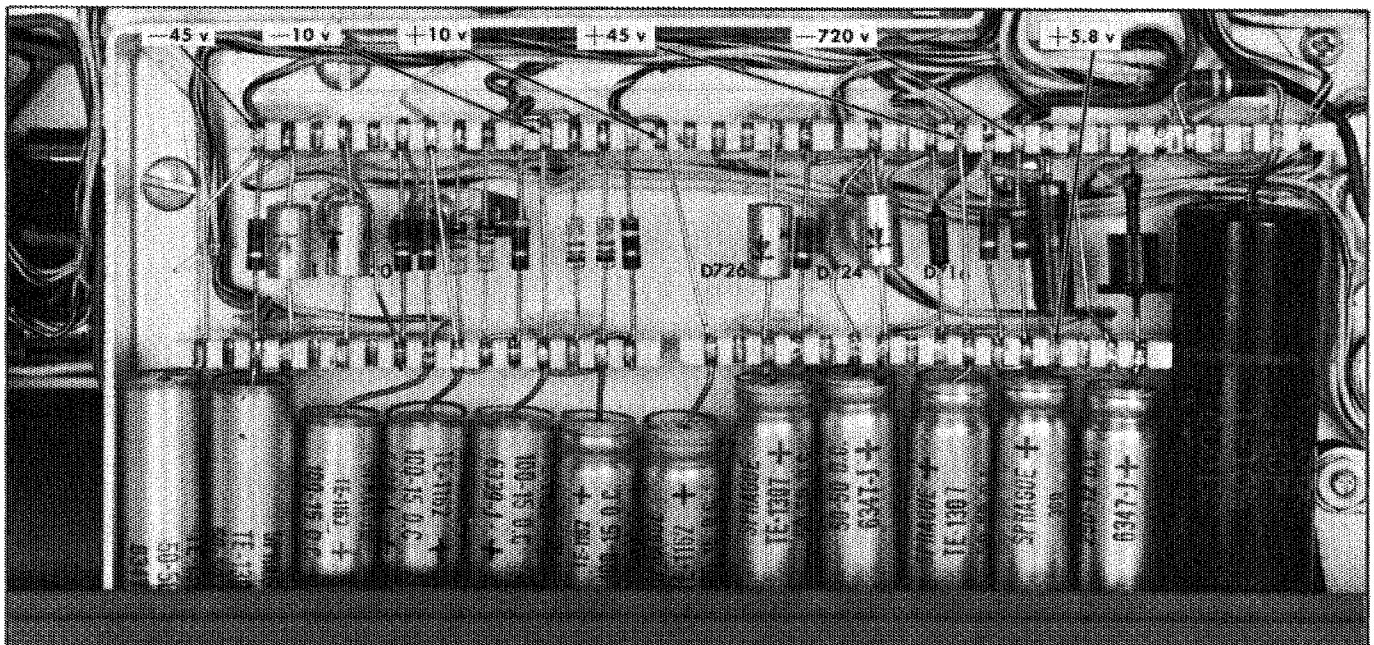

Fig. 6-2. Test point locations for checking the Converter output voltages (bottom right-side view).

Calibration — Type 321A

7. Adjust Stability (Time-Base Generator)

- a. Connect a 6" patch cord from the (Triggering) INPUT connector to the front-panel GND connector.

- b. Set the front-panel controls as follows:

TIME/DIV	.1 MILLI SEC
TRIGGERING	
INT-EXT	EXT
LEVEL	AUTO
STABILITY	Fully ccw

- c. Set the test oscilloscope Input Coupling switch to DC, the Volts/Div switch to .05 and the Time/Div switch to 2 Millisec.
- d. Connect a 10 \times probe (in place of the 1 \times probe) to the test oscilloscope.
- e. Connect the probe tip to the junction of D131 and the base of Q135 (see Fig. 6-6, page 6-8 in this section).
- f. Slowly rotate the STABILITY control in a clockwise direction until a point is reached where a trace is first displayed on the Type 321A crt. This is the point where automatic sweep triggering first occurs.
- g. Using the test oscilloscope controls, position the waveform so the base line of the negative-going sawtooth waveform (displayed on the test oscilloscope crt) is located at a convenient point near the bottom of the graticule. Note the location of the waveform base line displayed on the test oscilloscope crt.
- h. Continue to slowly rotate the STABILITY control in a clockwise direction until the trace displayed on the Type 321A crt brightens. This is the point where the time base free runs.
- i. Note the base-line position of the negative-going sawtooth waveforms displayed on the test oscilloscope crt.
- j. Rotate the STABILITY control in a counterclockwise direction until the base line of the test oscilloscope waveform display is located half way between the location noted in step 7g and the one noted in step 7i.
- k. Disconnect the test oscilloscope 10 \times probe and the patch cord.

NOTE

As an alternative method for use in the field when a test oscilloscope is not available, the STABILITY control can be adjusted with acceptable accuracy by setting the control half way between the point where the trace first appeared (as in step 7f) and the point where the trace brightens (as in step 7h).

8. Adjust Vertical Gain (Vertical Amplifier)

- a. Set the VOLTS/DIV switch to the CAL 4 DIV position.

- b. Set the INT-EXT switch to INT and the TIME/DIV switch to .5 MILLI SEC. Adjust the Type 321A CRT controls for a stable well defined display.
- c. Approximately 4 divisions of signal should be displayed. Adjust the VERT GAIN R468 control (see Fig. 6-5) for exactly 4 divisions of vertical deflection.
- d. As an extra check to setting the gain, set the VOLTS/DIV switch to .1 and connect the CAL OUT 500 MV jack to the (Vertical Amplifier) INPUT connector through the binding-post adapter and the 6" patch cord. The displayed signal should now be five divisions in amplitude.
- e. Disconnect the binding post adapter and patch cord.

9. Adjust High-Frequency Compensation C508 (Vertical Amplifier)

- a. Turn on the Type 105 Square-Wave Generator or equivalent. Set the Type 105 for an output frequency of 400 kc and the signal output to minimum.
- b. Connect the following items, starting from the Type 105 signal output connector, in this order—50-ohm coaxial cable, 10:1 attenuator, and 50-ohm termination—to the Type 321A (Vertical Amplifier) INPUT connector.
- c. Set the Type 321A VOLTS/DIV switch to .01 and the TIME/DIV switch to .5 μ sec.
- d. Set the Type 105 output amplitude to produce a display 4 major divisions in amplitude on the Type 321A.
- e. Adjust C508 (see Fig. 6-5) for best square-wave response; that is, for squarest leading top corner on the waveform.
- f. Disconnect the Type 105 signal from the Type 321A.

10. Adjust Probe and VOLTS/DIV Attenuator (Vertical Amplifier)

- a. Set the TIME/DIV switch to 1 MILLI SEC.
- b. Connect the cable end of a P6006 Probe to the (Vertical Amplifier) INPUT connector.
- c. Set the Type 105 for an output frequency of 1 kc and the signal output to minimum.
- d. Connect the probe tip through a 50-ohm termination and 10:1 attenuator (in that order) to the Type 105 signal output connector. Use adapters, if needed, to make proper signal and ground connections between the two instruments.
- e. Set the Type 105 signal output to produce a deflection of about 4 major divisions on the Type 321A crt.
- f. Compensate the probe as instructed under "Use of Probes" in Section 3 and illustrated in Fig. 3-7.
- g. Set the VOLTS/DIV switch to .02.
- h. Adjust the output amplitude of the Type 105 so the display is about 4 divisions in amplitude.

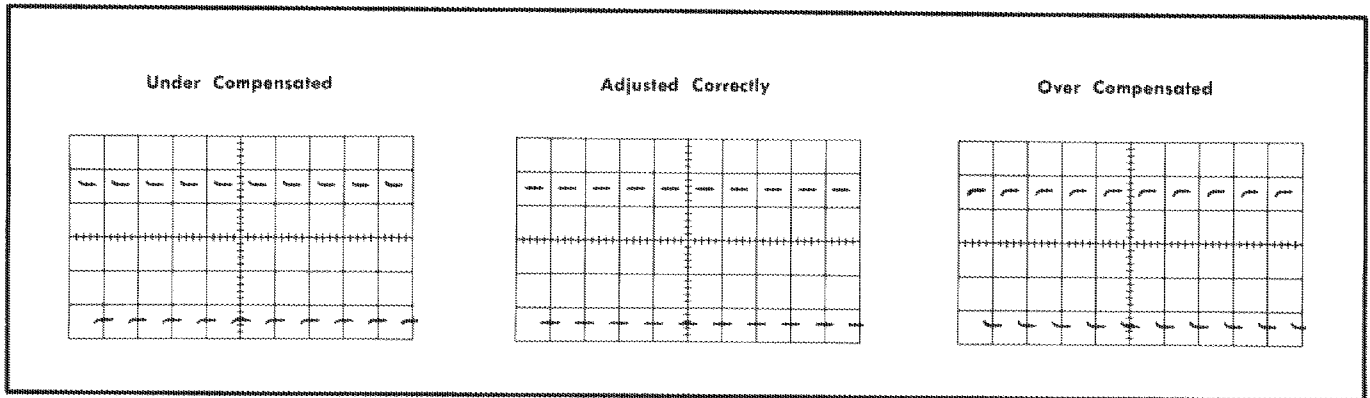

Fig. 6-3. Standardizing the input time constant.

- i. Using the information given in Table 6-2, adjust the two capacitors for each position (starting with the .02 VOLTS/DIV position) for best square-wave response. Location of the variable capacitors is shown in Fig. 6-5. Then, continue in a similar manner for the remaining VOLTS/DIV switch positions listed in the table. Maintain 4 divisions of deflection for each switch position providing the generator has sufficient output.

- j. Turn off the Type 105; disconnect the probe from the Type 105 and the Type 321A.

11. Check Frequency Response (Vertical Amplifier)

- a. Set the Attenuator switch of the Type 190A (or 190B or equivalent) Constant-Amplitude Signal Generator to the 0.1-volt peak-to-peak position.
- b. Connect the Type 190A Attenuator unit through a 50-ohm termination to the Type 321A (Vertical Amplifier) INPUT connector. Use a connector adapter, if needed, to make proper connections.
- c. Set the Signal Generator for an output frequency of 50 kc.
- d. Set up the Type 321A front-panel controls as follows:
 (TRIGGERING) LEVEL FREE RUN
 VARIABLE (TIME/DIV) CALIB
 VOLTS/DIV .01
 VARIABLE (VOLTS/DIV) CALIB
- e. Adjust the Type 190A to produce a deflection of exactly 4 major divisions on the Type 321A.
- f. Using the VERTICAL POSITION control, position the display so the deflection extends over the middle 4 divisions.

TABLE 6-2

Input Time-Constant Standardization and Attenuator Compensation

VOLTS/DIV Switch Position	Adjust for Optimum Flat Top (see Fig. 6-3)	Adjust for Optimum Leading Square Corner (see Fig. 6-4)
.02	C418A	C418C
.05*	C416A	C416C
.1	C414A	C414C
1**	C412A	C412C
10***	C410A	C410C

* Remove the 10:1 attenuator for this and remaining switch positions. Turn off the Type 105 dc output when removing the attenuator to avoid a shock hazard.

** Remove the 50-ohm termination for this and following switch position. Avoid shock hazard as described previously.

*** Maximum amplitude of the display is 1 major division since 100 volts is the maximum output amplitude from the Type 105.

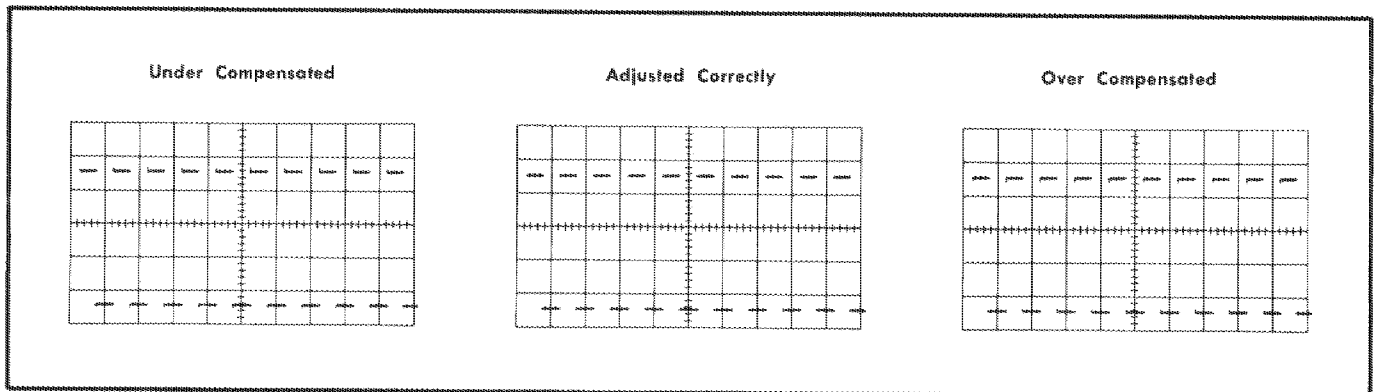

Fig. 6-4. Compensating the Attenuator high-frequency response.

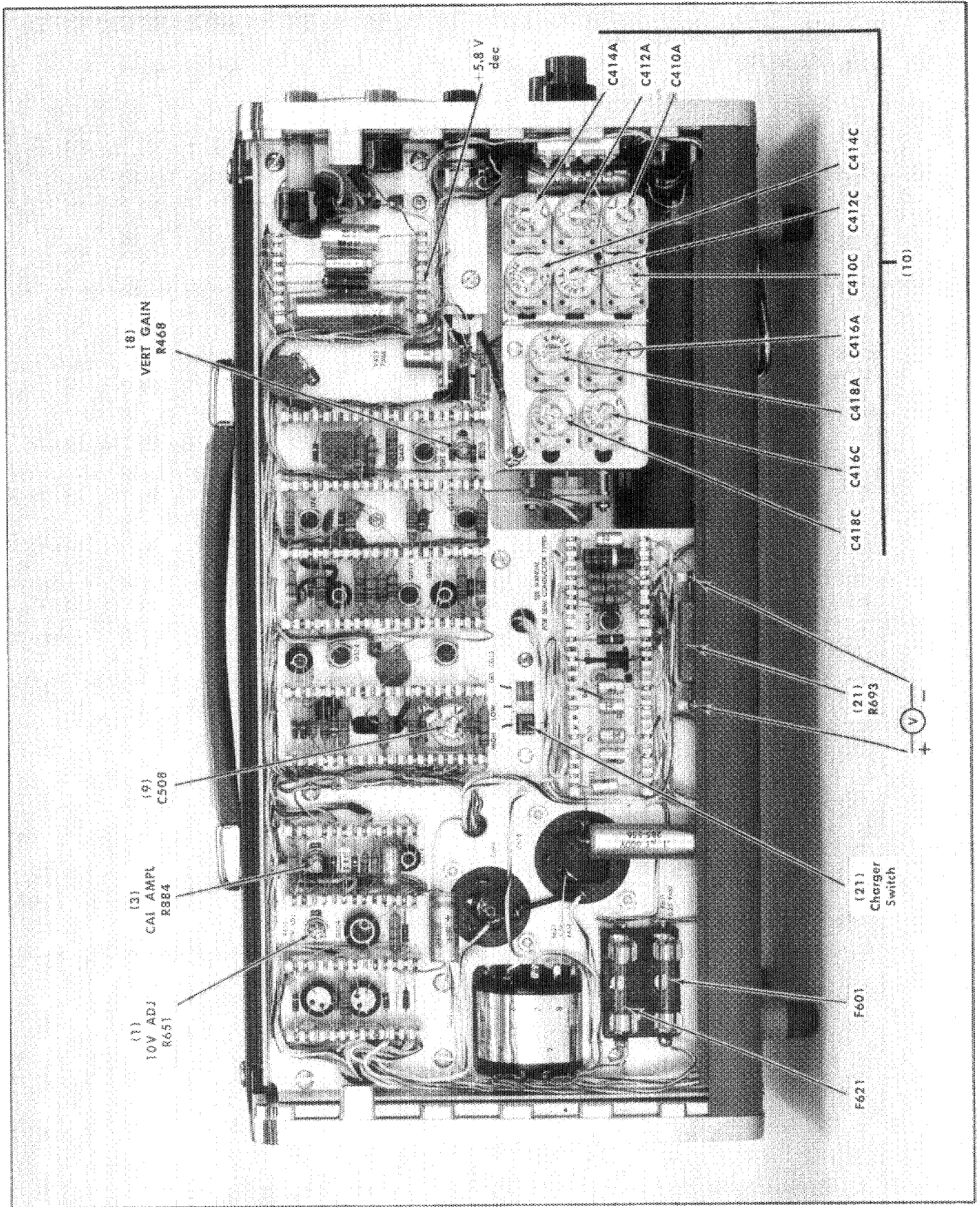

Fig. 6-5. Left-side view of the Type 321A Oscilloscope. The numbers in parenthesis refer to steps in the Calibration procedure.

- g. Increase the Signal Generator output frequency to 6 mc.
- h. The deflection should now be 2.8 major divisions or more. This is equivalent to an upper bandpass of 6 mc or more at 3 db down.
- i. Disconnect the Type 190A signal.

12. Adjust Horizontal Gain (Horizontal Amplifier)

- a. Set up the front-panel controls of the Type 321A as follows:

TIME/DIV	1 MILLI SEC
VARIABLE (TIME/DIV)	CALIB
5X MAG	Knob pushed in
TRIGGERING	
INT-EXT	INT
AC-DC	AC
SLOPE	+
AC-DC-GND	DC

- b. Apply 1-millisecond and 100 μ sec markers from the Type 180A Time-Mark Generator, or equivalent, through a coaxial cable to the Type 321A (Vertical Amplifier) INPUT connector.
- c. Set up the following controls for best presentation which is about 3 major divisions in amplitude: VOLTS/DIV, VARIABLE (VOLTS/DIV), VERTICAL POSITION, HORIZONTAL POSITION, (TRIGGERING) LEVEL, FOCUS, INTENSITY, ASTIGMATISM, and SCALE ILLUM.
- d. Adjust the HORIZ GAIN R338 control (see Fig. 6-6) for one highest (1 millisecond) marker per division. Use the HORIZONTAL POSITION control to align the 1-millisecond markers with the graticule lines. The circuit must calibrate between the 1- and 9-division graticule lines in this step and when performing steps 15, 17, and 18.

13. Adjust Sweep Length (Time-Base Generator)

- a. Using the HORIZONTAL POSITION control, position the 11th 1-millisecond marker (located at the 10-division graticule line) to graticule center.
- b. Adjust the SWEEP LENGTH R176 control (see Fig. 6-6) for five short (100- μ sec) markers after the 11th 1-millisecond marker. This is equivalent to a sweep length of 10.5 major divisions.
- c. Position the display to start at the 0-division graticule marking.

14. Adjust Magnifier Gain (Horizontal Amplifier)

- a. Pull the 5X MAG knob to its outward position.
- b. Adjust the MAG GAIN R348 control (see Fig. 6-6) for 1 highest (1-millisecond) marker per 5 major divisions and 2 short (100- μ sec) markers per 1 major division.

Use the HORIZONTAL POSITION control to align the 1-millisecond markers with the 0-, 5-, and 10-major-division graticule lines.

15. Check Magnified Sweep Linearity (Horizontal Amplifier)

- a. Using the HORIZONTAL POSITION control, position the display to the right until the sweep starts at the 1-major-division graticule line.
- b. Check sweep linearity over the first 8-major-division portion of the display. Non-linearity should not exceed $\pm 2\%$ or ± 0.16 major division.
- c. Position the display to the left and check linearity for the remaining portions of the display. Non-linearity should not exceed $\pm 2\%$ over any 8-major-division portion of the display.

16. Check Normal-Magnified Sweep Registration (Horizontal Amplifier)

- a. Set the Type 180A for 5-millisecond time-marker output.
- b. Adjust the VOLTS/DIV, VARIABLE (VOLTS/DIV), and (TRIGGERING) LEVEL controls for a stable display about 3 major divisions in amplitude.
- c. Push the 5X MAG knob inward and position the display to start at the 0-division graticule line.
- d. Note the marker located at the center (5-division) graticule line. Using the HORIZONTAL POSITION control carefully position this marker so it coincides exactly behind the center graticule line.
- e. Pull the 5X MAG knob outward and note the distance that the marker shifted. Marker shift should be less than ± 2.5 major divisions.
- f. Push the 5X MAG knob inward.

17. Adjust .5 μ sec Sweep-Rate Timing (TIME/DIV Switch)

- a. Set the Type 180A for 1- μ sec time-marker output.
- b. Set the Type 321A TIME/DIV switch to .5 μ SEC.
- c. Set the VOLTS/DIV, VARIABLE (VOLTS/DIV), and (TRIGGERING) LEVEL controls for a stable display about 3 major divisions in amplitude.
- d. Adjust C160L (see Fig. 6-6) for 1 marker per 2 major divisions over the center 8-major division portion of the graticule.

18. Check Sweep-Rate Timing Accuracy (TIME/DIV Switch)

- a. Table 6-3 lists the time markers to be applied for the indicated setting of the TIME/DIV switch, and the number of markers per division to be observed for each setting. There are no adjustments to be made in this step. This is a check of the TIME/DIV switch and associated circuitry; particularly the R160- and C160-series components that are switched into the circuit.

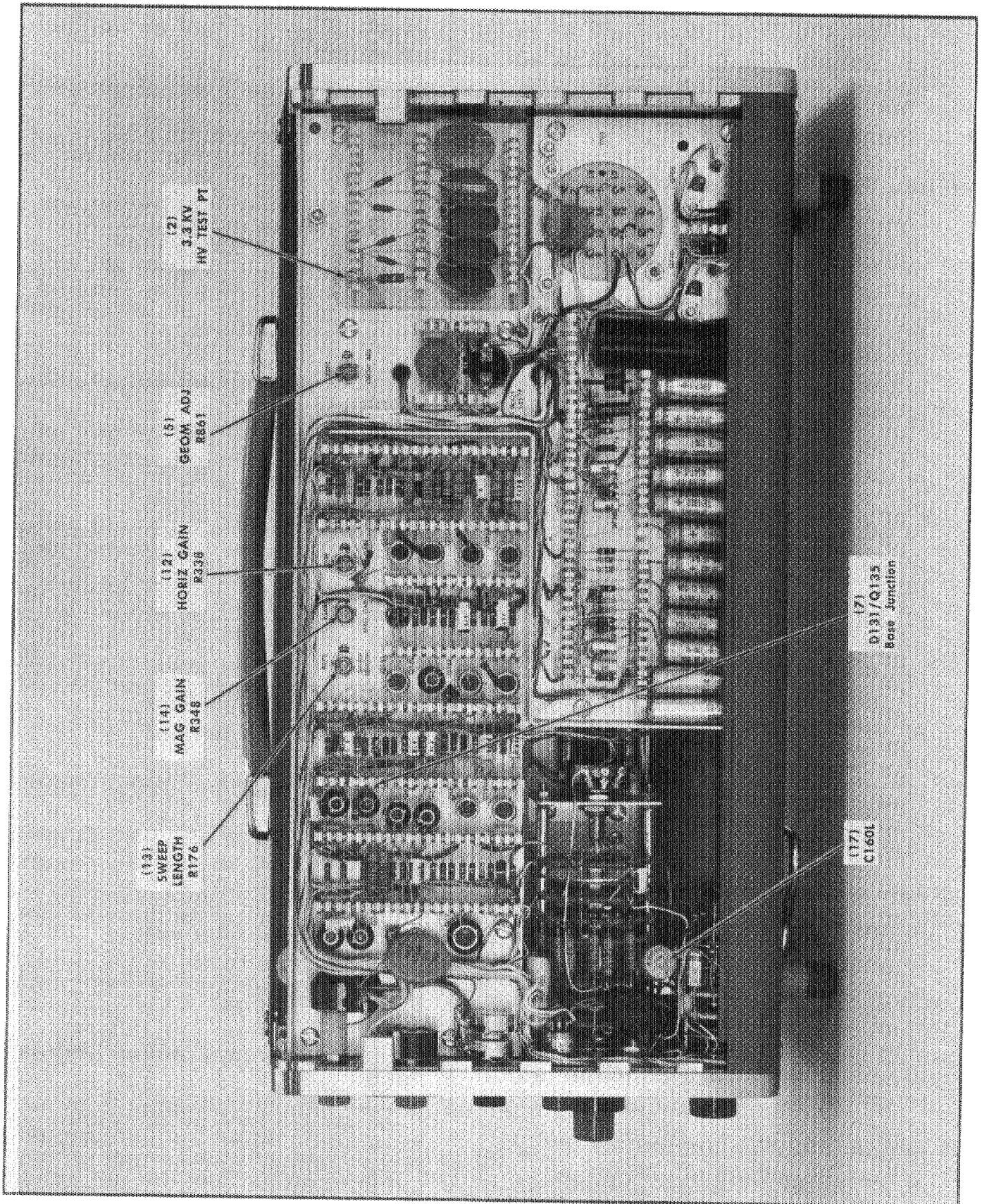

Fig. 6-6. Right-side view of the Type 321A Oscilloscope. The numbers in parenthesis refer to steps in the Calibration procedure.

TABLE 6-3

TIME/DIV Switch Position	Time Markers from Type 180A	Markers for Major Division (Accuracy $\pm 3\%$)
1 μ SEC	1 μ sec	1
2 μ SEC	1 μ sec	2
5 μ SEC	5 μ sec	1
10 μ SEC	10 μ sec	1
20 μ SEC	10 μ sec	2
50 μ SEC	50 μ sec	1
.1 MILLI SEC	100 μ sec	1
.2 MILLI SEC	100 μ sec	2
.5 MILLI SEC	500 μ sec	1
1 MILLI SEC	1 msec	1
2 MILLI SEC	1 msec	2
5 MILLI SEC	5 msec	1
10 MILLI SEC	10 msec	1
20 MILLI SEC	10 msec	2
50 MILLI SEC	50 msec	1
.1 SEC	100 msec	1
.2 SEC	100 msec	2
.5 SEC	500 msec	1

b. Disconnect the Type 180A signal.

19. Check External Horizontal Deflection Factor (Horizontal Amplifier)

- a. Set the TIME/DIV switch to .1 MILLI SEC, the VOLTS/DIV switch to 1, and the VARIABLE (VOLTS/DIV) to CALIB.
- b. Apply a 5-volt peak-to-peak 50-kc signal from the Type 190A, or equivalent, (through a suitable connector adapter, if needed) to the Type 321A (Vertical Amplifier) INPUT connector.
- c. Adjust the Signal Generator output amplitude to obtain exactly 5 major divisions of vertical deflection on the Type 321A crt. Use the (TRIGGERING) LEVEL control to make the display stable and the VERTICAL POSITION control to center the display while setting up the Type 321A to obtain the correct deflection. Adjust the INTENSITY control for pleasing display brightness.

NOTE

The Type 190A is now set up so its output amplitude is exactly 5 volts peak-to-peak ($\pm 3\%$). This signal can now be used to check the external horizontal deflection factor. Do not move the Type 190A control until steps 19d through 19h are completed.

- d. Disconnect the Type 190A signal from the (Vertical Amplifier) INPUT connector.
- e. Apply the Type 190A signal through a suitable clip-lead adapter to the Type 321A EXT HORIZ INPUT connector. Connect the ground lead of the clip-lead adapter to the Type 321A GND connector.

- f. Set the TIME/DIV switch to EXT HORIZ INPUT and pull the 5 \times MAG knob outward.
- g. Set the VERTICAL POSITION and HORIZONTAL POSITION controls so the trace is located near graticule center. Use the INTENSITY control to adjust the brightness of the trace to a suitable level.
- h. Check that the horizontal deflection of the trace is 5 major divisions long within a tolerance of $\pm 10\%$ or ± 0.5 major division.

20. Check External Horizontal Frequency Response (Horizontal Amplifier)

- a. Reduce the output amplitude of the Type 190A until the horizontal deflection of the trace is exactly 4 major division long.
- b. Increase the output frequency of the Type 190A until there are 2.8 major divisions of horizontal deflection.
- c. Check the Type 190A output frequency. The frequency should be 1 mc or higher.
- d. Set the TIME/DIV switch to 1 MILLI SEC and push the 5 \times MAG knob to the inward position.
- e. Disconnect the Type 190A signal.

21. Check Battery Charger (Regulator Circuit)

This is an optional check that should be made if you plan to operate the Type 321A from its internal rechargeable cells. This step checks the charging current by measuring the voltage drop across R693, a resistor connected in series with the batteries.

- a. Set the POWER switch to TRICKLE.
- b. Disconnect the ac line cord from the Type 321A and insert rechargeable cells in the battery holder.
- c. Reconnect the line cord to the Type 321A. Check that the autotransformer is set to design-center line voltage.
- e. Connect the dc voltmeter across R693. See Fig. 6-5 for location of R693 and polarity of voltage. Use Table 6-4 as a guide for typical voltage readings that should be obtained for the various switch positions.

TABLE 6-4

POWER Switch Position	Charger Switch Position	Typical Voltage Reading
TRICKLE	LOW	4.45
	HIGH	2.2
	DRY CELLS	0
FULL	LOW	23.4
	HIGH	19.4
	DRY CELLS	0
EXT ON	LOW	3.2
	HIGH	1.6
	DRY CELLS	0

SECTION 7

PARTS LIST and DIAGRAMS

PARTS ORDERING INFORMATION

Replacement parts are available from or through your local Tektronix Field Office.

Changes to Tektronix instruments are sometimes made to accommodate improved components as they become available, and to give you the benefit of the latest circuit improvements developed in our engineering department. It is therefore important, when ordering parts, to include the following information in your order: Part number including any suffix, instrument type, serial number, and modification number if applicable.

If a part you have ordered has been replaced with a new or improved part, your local Tektronix Field Office will contact you concerning any change in part number.

ABBREVIATIONS AND SYMBOLS

a or amp	amperes	mm	millimeter
BHS	binding head steel	meg or M	megohms or mega (10 ⁶)
C	carbon	met.	metal
cer	ceramic	μ	micro, or 10 ⁻⁶
cm	centimeter	n	nano, or 10 ⁻⁹
comp	composition	Ω	ohm
cps	cycles per second	OD	outside diameter
crt	cathode-ray tube	OHS	oval head steel
CSK	counter sunk	p	pico, or 10 ⁻¹²
dia	diameter	PHS	pan head steel
div	division	piv	peak inverse voltage
EMC	electrolytic, metal cased	plstc	plastic
EMT	electrolytic, metal tubular	PMC	paper, metal cased
ext	external	poly	polystyrene
f	farad	Prec	precision
F & I	focus and intensity	PT	paper tubular
FHS	flat head steel	PTM	paper or plastic, tubular, molded
Fil HS	fillister head steel	RHS	round head steel
g or G	giga, or 10 ⁹	rms	root mean square
Ge	germanium	sec	second
GMV	guaranteed minimum value	Si	silicon
h	henry	S/N	serial number
hex	hexagonal	t or T	tera, or 10 ¹²
HHS	hex head steel	TD	toroid
HSS	hex socket steel	THS	truss head steel
HV	high voltage	tub.	tubular
ID	inside diameter	v or V	volt
incd	incandescent	Var	variable
int	internal	w	watt
k or K	kilohms or kilo (10 ³)	w/	with
kc	kilocycle	w/o	without
m	milli, or 10 ⁻³	WW	wire-wound
mc	megacycle		

SPECIAL NOTES AND SYMBOLS

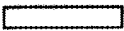
X000	Part first added at this serial number.
000X	Part removed after this serial number.
*000-000	Asterisk preceding Tektronix Part Number indicates manufactured by or for Tektronix, or reworked or checked components.
Use 000-000	Part number indicated is direct replacement.
	Internal screwdriver adjustment.
	Front-panel adjustment or connector.

FRONT & REAR

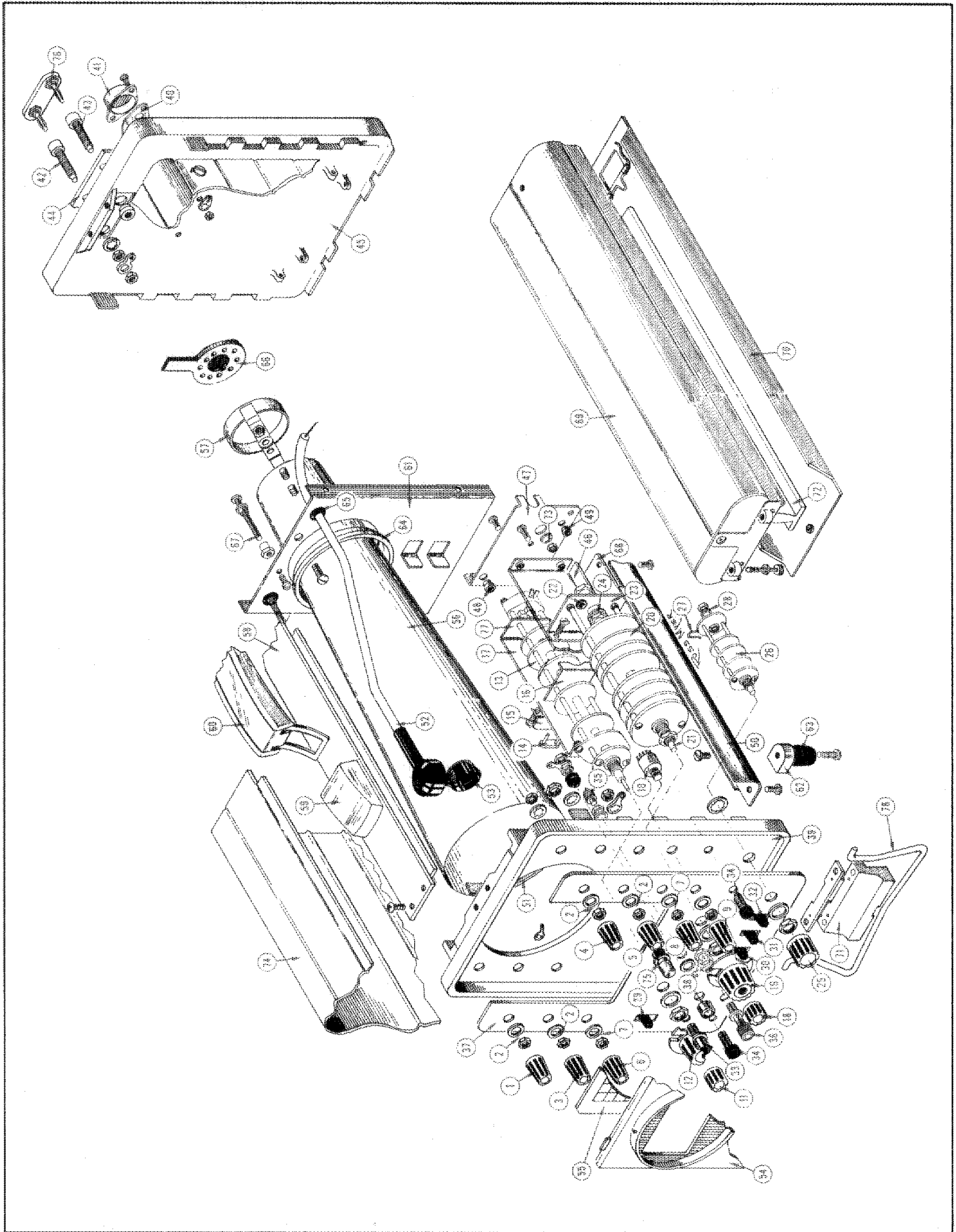

FRONT & REAR

REF. NO.	PART NO.	SERIAL/MODEL NO.		QTY.	DESCRIPTION
		EFF.	DISC.		
1	366-203			1	KNOB, gray — FOCUS
	-----			-	Includes:
	213-075			1	SCREW, set, 4-40 x 3/32 inch HSS
2	-----			-	Mounting Hardware For Pot:
	210-046			1	LOCKWASHER, internal, .400 OD x .261 ID
	210-583			1	NUT, hex, 1/4-32 x 5/16 inch
	210-940			1	WASHER, 1/4 ID x 3/8 inch OD
3	366-203			1	KNOB, gray — ASTIGMATISM
	-----			-	Includes:
	213-075			1	SCREW, set, 4-40 x 3/32 inch HSS
4	366-203			1	KNOB, gray — INTENSITY
	-----			-	Includes:
	213-075			1	SCREW, set, 4-40 x 3/32 inch HSS
5	366-203			1	KNOB, gray — SCALE ILLUM
	-----			-	Includes:
	213-075			1	SCREW, set, 4-40 x 3/32 inch HSS
6	366-270			1	KNOB, charcoal — VERTICAL POSITION
	-----			-	Includes:
	213-075			1	SCREW, set, 4-40 x 3/32 inch HSS
7	-----			-	Mounting Hardware For Pot:
	210-046			1	LOCKWASHER, internal, .400 OD x .261 ID
	210-223			1	LUG, solder, 1/4 inch
	210-583			1	NUT, hex, 1/4-32 x 5/16 inch
8	366-270			1	KNOB, charcoal — HORIZONTAL POSITION
	-----			-	Includes:
	213-075			1	SCREW, set, 4-40 x 3/32 inch HSS
9	366-270			1	KNOB, charcoal — POWER ON
	-----			-	Includes:
	213-075			1	SCREW, set, 4-40 x 3/32 inch HSS
10	260-617			1	SWITCH, unwired — POWER ON
	-----			-	Mounting Hardware: (not included)
	210-583			1	NUT, hex, 1/4-32 x 5/16 inch
	210-940			1	WASHER, 1/4 ID x 3/8 inch OD
11	366-081			1	KNOB, red — VARIABLE
	-----			-	Includes:
	213-004			1	SCREW, set, 6-32 x 3/16 inch HSS
12	366-230			1	KNOB, charcoal — VOLTS/DIV
	-----			-	Includes:
	213-004			1	SCREW, set, 6-32 x 3/16 inch HSS
13	262-661			1	SWITCH, wired — VOLTS/DIV
	-----			-	Includes:
	260-625			1	SWITCH, unwired — VOLTS/DIV
14	214-153			10	FASTENER, delrin
15	337-332			1	SHIELD, attenuator
	-----			-	Mounting Hardware: (not included)
	211-008			2	SCREW, 4-40 x 1/4 inch BHS
16	407-060			1	BRACKET, attenuator

FRONT & REAR (Cont'd)

REF. NO.	PART NO.	SERIAL/MODEL NO.		QTY.	DESCRIPTION
		EFF.	DISC.		
17	441-0581-00			1	CHASSIS, attenuator
	- - - - -			-	Mounting Hardware: (not included)
	210-0004-00			2	LOCKWASHER, internal, #4
	210-0406-00			2	NUT, hex, 4-40 x 3/16 inch
	211-0008-00			2	SCREW, 4-40 x 3/16 inch BHS
	210-0201-00			1	LUG, solder, SE #4
	- - - - -			-	Mounting Hardware For Switch: (not included)
	210-0012-00			1	LOCKWASHER, internal, 3/8 x 1/2 inch
	210-0413-00			1	NUT, hex, 3/8-32 x 1/2 inch
	210-0840-00			1	WASHER, .390 ID x 9/16 inch OD
	211-0008-00			2	SCREW, 4-40 x 1/4 inch BHS
18	366-0276-00			1	KNOB, red—VARIABLE
	- - - - -			-	Includes:
	213-0004-00			1	SCREW, set, 6-32 x 3/16 inch HSS
19	366-0230-00			1	KNOB, charcoal—TIME/DIV
	- - - - -			-	Includes:
	213-0004-00			1	SCREW, set, 6-32 x 3/16 inch HSS
20	262-0660-00			1	SWITCH, wired—TIME/DIV
	- - - - -			-	Includes:
	260-0376-00			1	SWITCH, unwired—TIME/DIV
21	384-0197-00			1	ROD, extension
	- - - - -			-	Mounting Hardware: (not included)
	213-0075-00			1	SCREW, set, 4-40 x 3/32 inch HSS
22	348-0055-00			1	GROMMET, nylon, 1/4 inch
23	406-0024-00			1	BRACKET
	- - - - -			-	Mounting Hardware: (not included)
	210-0006-00			2	LOCKWASHER, internal, #6
	210-0407-00			2	NUT, hex, 6-32 x 1/4 inch
24	- - - - -			-	Mounting hardware For Pot:
	210-0413-00			2	NUT, hex, 3/8-32 x 1/2 inch
	210-0840-00			1	WASHER, .390 ID x 9/16 inch OD
	- - - - -			-	Mounting Hardware For Switch: (not included)
	210-0012-00			1	LOCKWASHER, internal, 3/8 x 1/2 inch
	210-0413-00			1	NUT, hex, 3/8-32 x 9/16 inch
	211-0504-00			2	SCREW, 6-32 x 1/4 inch
25	366-0148-00			1	KNOB, charcoal—AUTO (LEVEL)
	- - - - -			-	Includes:
	213-0004-00			1	SCREW, set, 6-32 x 3/16 inch HSS
26	262-0662-00			1	SWITCH, wired—AUTO (LEVEL)
	- - - - -			-	Includes:
	260-0296-00			1	SWITCH, unwired—AUTO (LEVEL)
27	376-0014-00			1	COUPLING
28	- - - - -			-	Mounting Hardware For Miniature Pot:
	210-0046-00			1	LOCKWASHER, internal, .400 OD x .261 ID
	210-0583-00			2	NUT, hex, brass, 1/4-32 x 5/16 inch
	- - - - -			-	Mounting Hardware For Switch: (not included)
	210-0012-00			1	LOCKWASHER, internal, 3/8 x 1/2 inch
	210-0413-00			1	NUT, hex, 3/8-32 x 1/2 inch
	210-0840-00			1	WASHER, .390 ID x 9/16 inch OD

FRONT & REAR (Cont'd)

REF. NO.	PART NO.	SERIAL/MODEL NO.		QTY.	DESCRIPTION
		EFF.	DISC.		
29	260-0448-00			1	SWITCH, unwired—AC-DC-GND
				-	Mounting Hardware: (not included)
	210-0406-00			2	NUT, hex, 4-40 x 3/16 inch
30	260-0449-00			1	SWITCH, unwired—INT-EXT
				-	Mounting Hardware: (not included)
	210-0406-00			2	NUT, hex, 4-40 x 3/16 inch
31	260-0449-00			1	SWITCH, unwired—AC-DC
				-	Mounting Hardware: (not included)
	210-0406-00			2	NUT, hex, 4-40 x 3/16 inch
32	260-0447-00			1	SWITCH, unwired—SLOPE
				-	Mounting Hardware: (not included)
	210-0406-00			2	NUT, hex, 4-40 x 3/16 inch
33	131-0106-00			1	CONNECTOR, chassis mounted, BNC
				-	Mounting Hardware: (not included)
	210-0255-00			1	LUG, solder
	210-0423-00			1	NUT, hex, 3/8-32 x 1/2 inch
34	136-0140-00			3	SOCKET, banana jack ass'y
				-	Mounting Hardware For Each: (not included)
	210-0223-00			1	LUG, solder, 1/4 inch
	210-0465-00			2	NUT, hex, 1/4-32 x 3/8 inch
	210-0895-00			1	WASHER, insulating, black
35	150-0038-00			1	LIGHT, LOW BATTERIES
36	129-0053-00			1	POST, binding, assembly
				-	Includes:
	200-0103-00			1	CAP, binding post
	210-0011-00			1	LOCKWASHER, internal, 1/4 inch
	210-0455-00			1	NUT, hex, 1/4-28 x 3/8 inch
	355-0507-00			1	STEM, binding post adapter
37	333-0830-00			1	PANEL, front
38	358-0075-00			2	BUSHING, miniature pot
39	387-0940-00			1	PLATE, front
40	136-0135-00			1	SOCKET, 2 pin (not shown)
				-	mounting hardware: (not included w/socket)
	213-0113-00			2	SCREW, thread forming, 2-32 x 5/16 inch, RHS
	387-0345-00			1	PLATE, mica
41	200-0196-00			1	COVER, transistor
				-	Mounting Hardware: (not included)
	211-0510-00			2	SCREW, 6-32 x 3/8 inch BHS
42	136-0140-00			1	SOCKET, banana jack ass'y
				-	Mounting Hardware: (not included)
	210-0223-00			1	LUG, solder, 1/4 inch
	210-0465-00			2	NUT, hex, 1/4-32 x 3/8 inch
43	136-0139-00			1	SOCKET, banana jack ass'y
				-	Mounting Hardware: (not included)
	210-0223-00			1	LUG, solder, 1/4 inch
	210-0465-00			2	NUT, hex, 1/4-32 x 3/8-inch
	210-0898-00			1	WASHER, insulating, red
44	334-0715-00			1	TAG, crt grid
45	387-0948-00			1	PLATE, rear

FRONT & REAR (Cont'd)

REF. NO.	PART NO.	SERIAL/MODEL NO.		QTY.	DESCRIPTION
		EFF.	DISC.		
46	337-0652-00			1	SHIELD, switch
	-----			-	Mounting Hardware: (not included)
	211-0504-00			3	SCREW, 6-32 x 1/4 inch PHS
47	387-0938-00			1	PLATE, bulkhead, front
	-----			-	Includes:
	214-0210-00			1	SPOOL, solder assembly
	-----			-	Mounting Hardware: (not included)
	361-0007-00			1	SPACER
	-----			-	Mounting Hardware: (not included)
	211-0504-00			4	SCREW, 6-32 x 1/4 inch PHS
48	348-0056-00			1	GROMMET, 3/8 inch
49	348-0055-00			1	GROMMET, 1/4 inch
50	122-0123-00			2	ANGLE, rail bottom
	-----			-	Mounting Hardware For Each: (not included)
	211-0504-00			2	SCREW, 6-32 x 1/4 inch PHS
	334-0931-00			1	TAG, voltage rating (left rail, not shown)
51	124-0109-00			1	STRIP, felt, 4 1/16 inches
	124-0115-00			1	STRIP, felt, 2 3/8 inches
52	131-0084-00			1	CONNECTOR, cable, 12 inch anode
53	200-0197-00			1	COVER, crt anode
54	200-0584-00			1	COVER, graticule
55	331-0055-00			1	GRATICULE
56	337-0336-00			1	SHIELD, crt
	-----			-	Mounting Hardware: (not included)
	211-0504-00			2	SCREW, 6-32 x 1/4 inch PHS
57	343-0029-00			1	CLAMP, crt socket
	-----			-	Mounting Hardware: (not included)
	210-0457-00			4	NUT, keps, 6-32 x 5/16 inch
	210-0501-00			1	NUT, square, 10-32 x 3/8 inch
	210-0803-00			4	WASHER, 6L x 3/8 inch
	211-0534-00			4	SCREW, 6-32 x 5/16 inch PHS
	212-0557-00			1	SCREW, 10-32 x 1/2 inch RHS
58	381-0227-00			1	BAR, alum., extruded handle assembly
	-----			-	Includes:
59	344-0098-00			2	CLIP
	212-0566-00	1009	2799	2	SCREW, 10-32 x 5/16 inch RHS
	212-0507-00	2800		2	SCREW, 10-32 x 3/8 inch PHS
	210-0010-00	X2800		2	LOCKWASHER, internal, #10
60	367-0037-00			1	HANDLE
	-----			-	Mounting Hardware: (not included)
	211-0504-00			4	SCREW, 6-32 x 1/4 inch PHS
61	387-0941-00			1	PLATE, bulkhead, rear
	-----			-	Mounting Hardware: (not included)
	211-0504-00			4	SCREW, 6-32 x 1/4 inch PHS
	210-0202-00	X400		1	LUG, solder, SE6
62	348-0026-00			2	FOOT, gray, flip-stand pivot block, left
	348-0027-00			2	FOOT, gray, flip-stand pivot block, left
63	348-0062-00			4	FOOT, plastic
	-----			-	Mounting Hardware For Each: (not included)
	210-0457-00			1	NUT keps, 6-32 x 5/16 inch
	211-0532-00			1	SCREW, 6-32 x 3/4 inch Fil HS
64	348-0030-00			1	GROMMET, polyethylene, crt shield
65	348-0056-00			2	GROMMET, delrin
66	354-0095-00			1	RING, crt rotating

FRONT & REAR (Cont'd)

REF. NO.	PART NO.	SERIAL/MODEL NO.		QTY.	DESCRIPTION
		EFF.	DISC.		
67	- - - - -			-	Mounting Hardware For 5 Watt Resistor:
	210-0478-00			1	NUT, hex, alum., resistor mounting:
	210-0601-00			1	EYELET
	211-0507-00			1	SCREW, 6-32 x $\frac{5}{16}$ inch BHS
	211-0553-00			1	SCREW, 6-32 x $1\frac{1}{2}$ inches RHS, phillips
68	337-0654-00			1	SHIELD
	- - - - -			-	Mounting Hardware: (not included)
	211-0504-00			2	SCREW, 6-32 x $\frac{1}{4}$ inch BHS
69	352-0080-00			1	HOLDER, battery assembly
	- - - - -			-	Includes:
	210-0006-00			4	LOCKWASHER, internal, #6
	213-0045-00			6	SCREW, self-tapping, 4-40 x $\frac{5}{16}$ inch PHS phillips
	213-0133-00			4	SCREW, contact, 6-32
	214-0501-00			4	SPRING, contact
	352-0079-00			1	HOLDER, battery
	387-0967-00			1	PLATE, contact
70	387-0966-00			1	PLATE, bottom assembly
	- - - - -			-	Includes:
	210-0006-00			1	LOCKWASHER, internal, #6
	213-0131-00			1	SCREW, contact, 6-32
71	391-0060-00			1	BLOCK, contact assembly
72	361-0078-00			1	SPACER, battery
73	- - - - -			-	Mounting Hardware For Capacitor:
	210-0018-00			1	LOCKWASHER, steel, $\frac{5}{16}$ inch
	220-0415-00			1	NUT, hex, brass, $\frac{5}{16}$ -32 x $\frac{7}{16}$ inch
74	387-0969-00			2	PLATE, cabinet, side
	- - - - -			-	Each Includes:
	105-0009-00			2	STOP, $\frac{5}{32}$ ID x $1\frac{1}{32}$ inch OD
	210-0470-00			2	NUT, cabinet fastener
	210-0870-00			2	WASHER, $\frac{9}{64}$ ID x $\frac{5}{16}$ inch OD
	213-0040-00			2	SCREW, fastening, 6-32 x $\frac{1}{2}$ inch
75	150-0020-00			1	BULB, pilot light assembly
76	134-0012-00			1	PLUG, banana, male, twin
77	406-0020-00			1	BRACKET, attenuator
78	348-0024-00			1	FOOT

CHASSIS

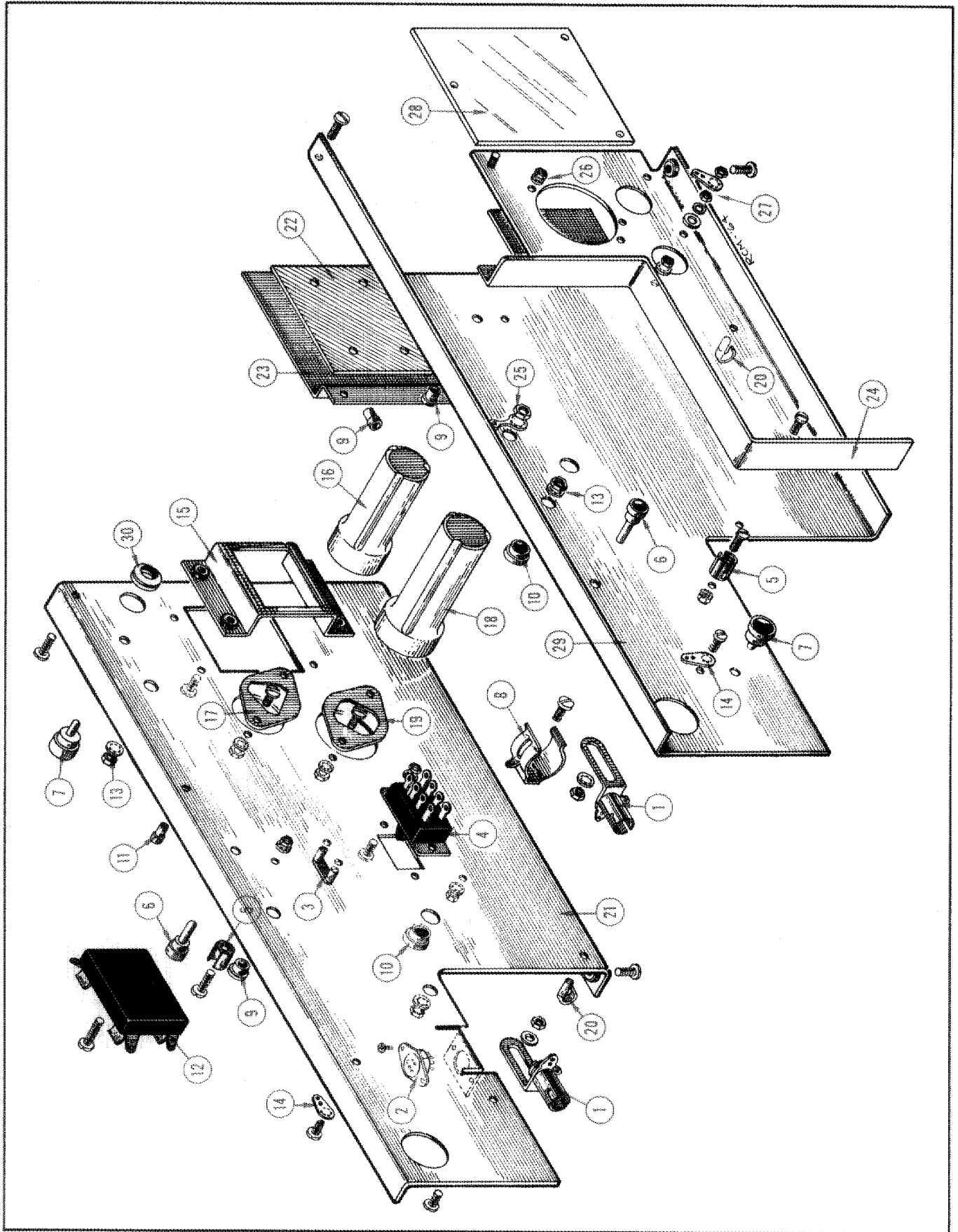

CHASSIS

REF. NO.	PART NO.	SERIAL/MODEL NO.		QTY.	DESCRIPTION
		EFF.	DISC.		
1	136-035			2	SOCKET, graticule light
	- - - -			-	Mounting Hardware: (not included)
	210-457			1	NUT, hex, 6-32 x $\frac{5}{16}$ inch
	210-803			1	WASHER, 6L x $\frac{3}{8}$ inch
	211-510			1	SCREW, 6-32 x $\frac{3}{8}$ inch BHS
2	136-101			1	SOCKET, 5 pin
	- - - -			-	Mounting Hardware: (not included)
	213-055			2	SCREW, 2-32 x $\frac{3}{16}$ inch PHS, phillips
3	214-153			1	FASTENER, snap
4	260-450			1	SWITCH, unwired — Charger
	- - - -			-	Mounting Hardware: (not included)
	210-004			2	LOCKWASHER, internal, #4
	210-406			2	NUT, hex, 4-40 x $\frac{3}{16}$ inch
	211-008			2	SCREW, 6-32 x $\frac{1}{4}$ inch BHS
5	343-044			16	CLAMP, mounting
	- - - -			-	Mounting Hardware For Each: (not included)
	210-586			1	NUT, hex, 4-40 x $\frac{1}{4}$ inch
	211-008			1	SCREW, 4-40 x $\frac{1}{4}$ inch BHS
6	352-077			4	HOLDER, transistor
7	352-078			11	HOLDER, transistor
8	344-016			1	CLAMP, $\frac{1}{32}$ x $\frac{1}{16}$ inches diameter
	- - - -			-	Mounting Hardware: (not included)
	210-006			1	LOCKWASHER, internal, #6
	210-407			1	NUT, hex, 6-32 x $\frac{1}{4}$ inch
	211-504			1	SCREW, 6-32 x $\frac{1}{4}$ inch BHS
9	348-055			3	GROMMET, plastic, $\frac{1}{4}$ inch diameter
10	348-056			3	GROMMET, delrin, .406 OD x .353 inch ID
11	348-031			4	GROMMET, polypropylene, $\frac{1}{4}$ inch diameter
12	352-025			1	HOLDER, fuse, dual 3AG
	- - - -			-	Mounting Hardware: (not included)
	211-507			2	SCREW, 6-32 x $\frac{5}{16}$ inch BHS
13	- - - -			-	Mounting Hardware For Miniature Pot:
	210-046			1	LOCKWASHER, .400 OD x .261 inch ID
	210-583			1	NUT, hex, $\frac{1}{4}$ -32 x $\frac{5}{16}$ inch
	210-940			1	WASHER, $\frac{1}{4}$ ID x $\frac{3}{8}$ inch OD
14	210-202			7	LUG, solder, SE #6
	- - - -			-	Mounting Hardware For Each: (not included)
	213-044			1	SCREW, thread cutting, 5-32 x $\frac{3}{16}$ inch PHS, phillips
15	406-685			1	BRACKET, transformer
	- - - -			-	Mounting Hardware: (not included)
	211-507			4	SCREW, 6-32 x $\frac{5}{16}$ inch BHS
16	200-532			1	COVER, capacitor, polyethylene, $2\frac{1}{32}$ x 1 inch diameter
17	386-252			1	PLATE, fiber, small
	- - - -			-	Mounting Hardware: (not included)
	210-006			2	LOCKWASHER, internal, #6
	210-407			2	NUT, hex, 6-32 x $\frac{1}{4}$ inch
	211-534			2	SCREW, 6-32 x $\frac{5}{16}$ inch PHS with lockwasher
18	200-293			1	COVER, capacitor, polyethylene, $2\frac{9}{16}$ x 1.365 inches ID

Parts List — Type 321A

CHASSIS (Cont'd)

REF. NO.	PART NO.	SERIAL/MODEL NO.		QTY.	DESCRIPTION
		EFF.	DISC.		
19	386-254			1	PLATE, fiber, large
	- - - -			-	Mounting Hardware: (not included)
	210-006			2	LOCKWASHER, internal, #6
	210-407			2	NUT, hex, 6-32 x 1/4 inch
	211-534			2	SCREW, 6-32 x 5/16 inch PHS with lockwasher
20	343-088			3	CLAMP, cable, delrin
21	441-557			1	CHASSIS, power
	- - - -			-	Mounting Hardware: (not included)
	211-507			6	SCREW, 6-32 x 5/16 inch BHS
22	337-653			1	SHIELD, insulation
23	441-558			1	CHASSIS, high voltage
	- - - -			-	Mounting Hardware: (not included)
	211-507			4	SCREW, 6-32 x 5/16 inch BHS
24	337-655			1	SHIELD, sweep
	- - - -			-	Mounting Hardware: (not included)
	211-507			5	SCREW, 6-32 x 5/16 inch BHS
25	- - - -			-	Mounting Hardware For Miniature Pot:
	210-223			1	LUG, solder, 1/4 inch
	210-583			1	NUT, hex, 1/4-32 x 5/16 inch
26	- - - -			-	Mounting Hardware For Transformer:
	210-006			2	LOCKWASHER, internal, #6
	210-407			2	NUT, hex, 6-32 x 1/4 inch
27	- - - -			-	Mounting Hardware For Transistor:
	210-006			1	LOCKWASHER, internal, 6
	210-202			1	LUG, solder, SE #6
	210-407			4	NUT, hex, 6-32 x 1/4 inch
	210-811			4	WASHER, fiber, #6
	210-812			2	WASHER, fiber, #10
	211-511			2	SCREW, 6-32 x 1/2 inch BHS
28	337-651			1	SHIELD, high voltage
	- - - -			-	Mounting Hardware: (not included)
	210-586			3	NUT, keps, 4-40 x 1/4 inch
29	441-556			1	CHASSIS, sweep
	- - - -			-	Mounting Hardware: (not included)
	211-507			5	SCREW, 6-32 x 5/16 inch BHS
30	348-012			1	GROMMET, rubber, 5/8 inch

CABLE HARNESS & CERAMIC STRIPS

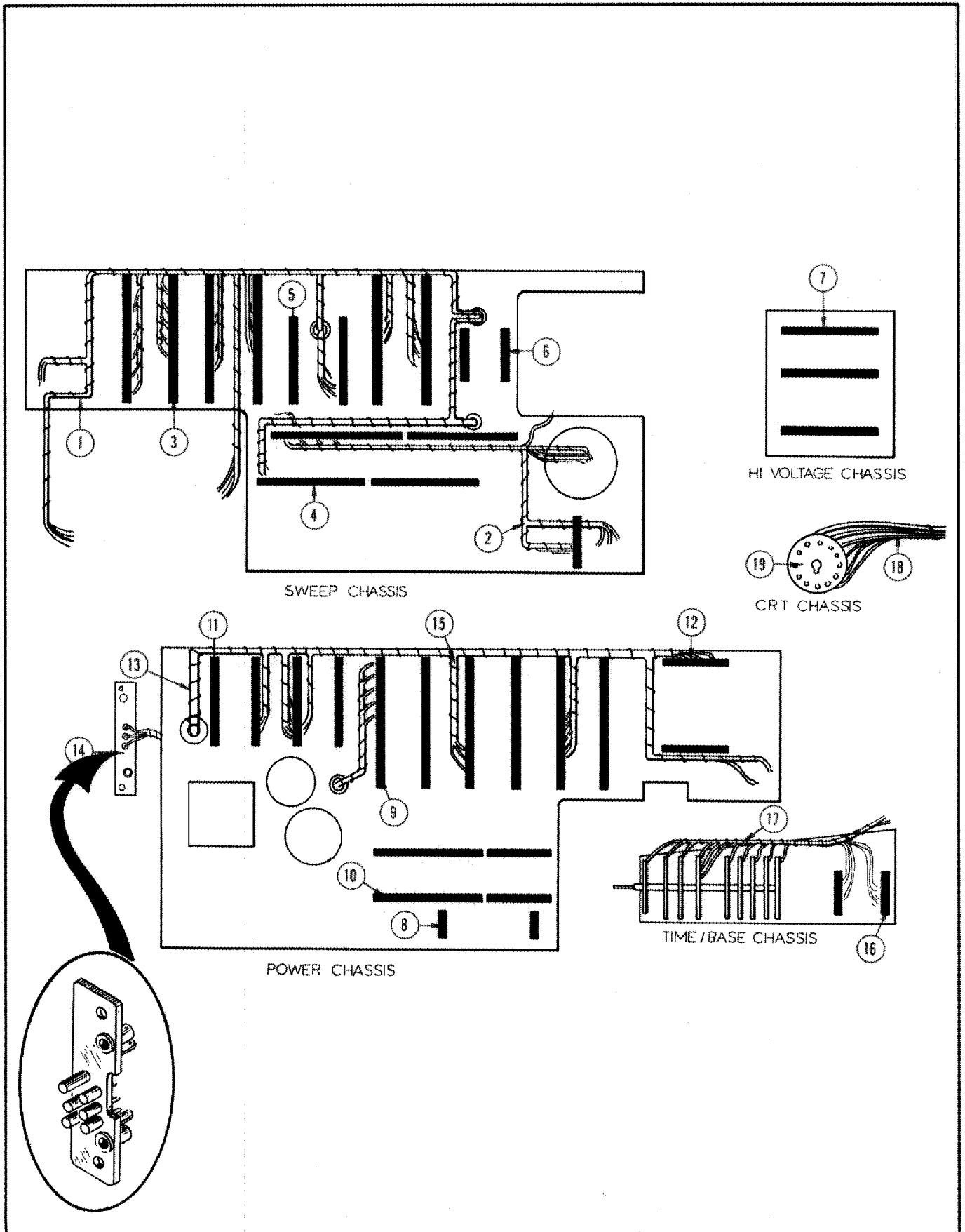

CABLE HARNESS & CERAMIC STRIPS

REF. NO.	PART NO.	SERIAL/MODEL NO.		QTY.	DESCRIPTION
		EFF.	DISC.		
1	179-0883-00	100	1999	1	CABLE HARNESS, sweep
	179-0883-01	2000		1	CABLE HARNESS, sweep
2	179-0886-00			1	CABLE HARNESS, transformer
3	124-0145-00			7	STRIP, ceramic, 7/16 inch x 20 notches
	-----			-	Each Includes:
	355-0046-00			2	STUD, nylon
	-----			-	Mounting Hardware For Each: (not included)
4	361-0007-00			2	SPACER, nylon
	124-0146-00			3	STRIP, ceramic, 7/16 inch x 16 notches
	-----			-	Each Includes:
	355-0046-00			2	STUD, nylon
5	-----			-	Mounting Hardware For Each: (not included)
	361-0007-00			2	SPACER, nylon
	124-0147-00			2	STRIP, ceramic, 7/16 inch x 13 notches
	-----			-	Each Includes:
6	355-0046-00			2	STUD, nylon
	-----			-	Mounting Hardware For Each: (not included)
	361-0007-00			2	SPACER, nylon
	124-0149-00			3	STRIP, ceramic, 7/16 inch x 7 notches
7	-----			-	Each Includes:
	355-0046-00			2	STUD, nylon
	-----			-	Mounting Hardware For Each: (not included)
	361-0009-00			2	SPACER, nylon
8	124-0092-00			2	STRIP, ceramic, 7/16 inch x 3 notches
	-----			-	Each Includes:
	355-0046-00			1	STUD, nylon
	-----			-	Mounting Hardware For Each: (not included)
9	361-0007-00			1	SPACER, nylon
	124-0145-00			6	STRIP, ceramic, 7/16 inch x 20 notches
	-----			-	Each Includes:
	355-0046-00			2	STUD, nylon
10	-----			-	Mounting Hardware For Each: (not included)
	361-0007-00			2	SPACER, nylon
	124-0146-00			2	STRIP, ceramic, 7/16 inch x 16 notches
	-----			-	Each Includes:
11	355-0046-00			2	STUD, nylon
	-----			-	Mounting Hardware For Each: (not included)
	361-0007-00			2	SPACER, nylon
	124-0147-00			4	STRIP, ceramic, 7/16 inch x 13 notches
	-----			-	Each Includes:
	355-0046-00			2	STUD, nylon
	-----			-	Mounting Hardware For Each: (not included)
	361-0007-00			2	SPACER, nylon

CABLE HARNESS & CERAMIC STRIPS (Cont'd)

REF. NO.	PART NO.	SERIAL/MODEL NO.		QTY.	DESCRIPTION
		EFF.	DISC.		
12	124-148			4	STRIP, ceramic, $\frac{7}{16}$ inch x 9 notches
	- - - -			-	Each Includes:
	355-046			2	STUD, nylon
	- - - -			-	Mounting Hardware For Each: (not included)
	361-007			2	SPACER, nylon
13	179-885			1	CABLE HARNESS, power connector
14	392-164			1	BOARD (AC/DC Connector)
15	179-882			1	CABLE, harness, vertical amplifier
16	124-149			2	STRIP, ceramic, $\frac{7}{16}$ inch x 7 notches
	- - - -			-	Each Includes:
	355-046			2	STUD, nylon
	- - - -			-	Mounting Hardware For Each: (not included)
	361-007			2	SPACER, nylon
17	179-884			1	CABLE, harness, timing switch
18	179-887			1	CABLE, harness, crt
	- - - -			-	Includes:
19	136-081			1	SOCKET, crt, 12 pin with 24 inch leads

STANDARD ACCESSORIES

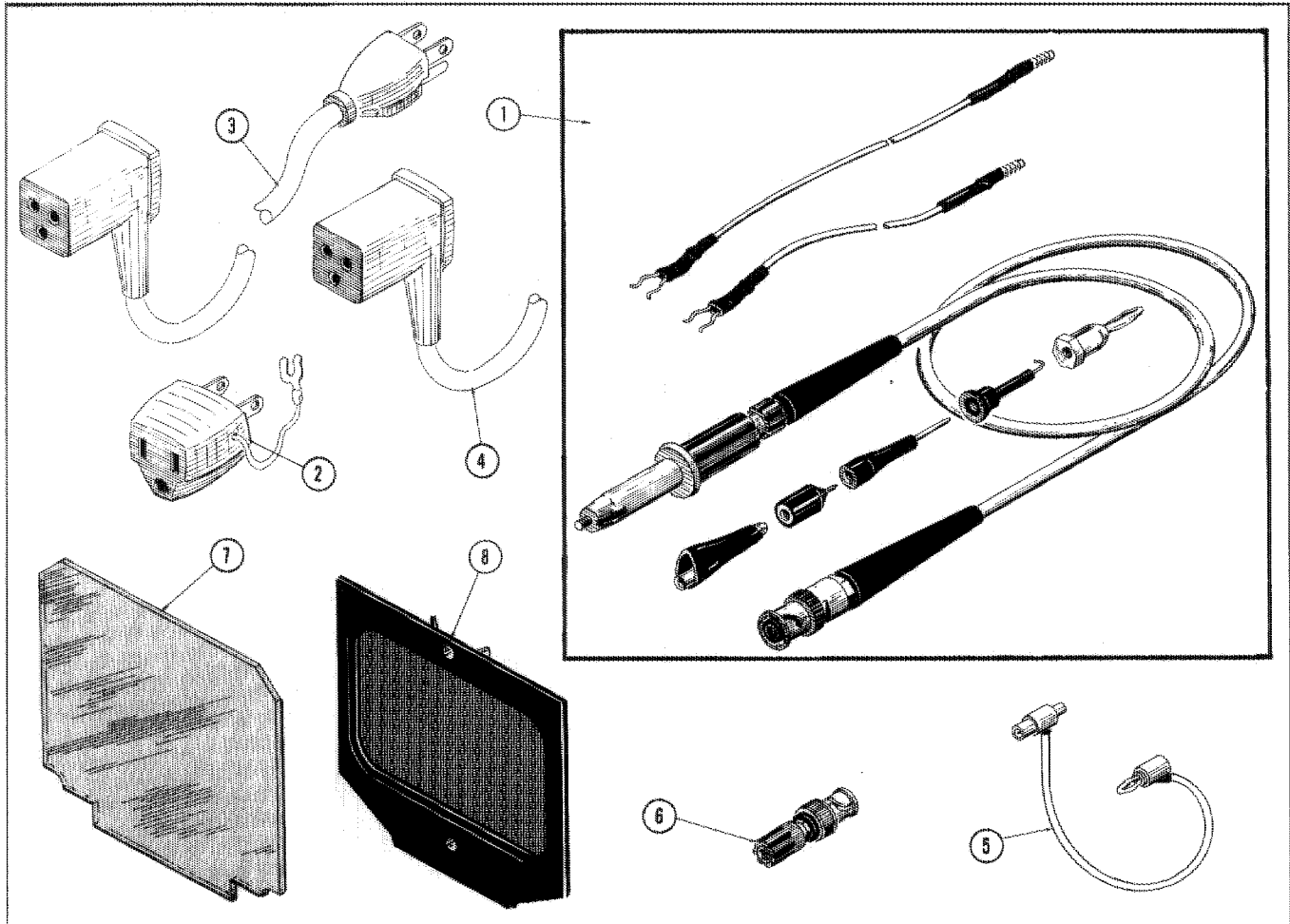

REF. NO.	PART NO.	SERIAL/MODEL NO.		QTY.	DESCRIPTION
		EFF.	DISC.		
1	010-0127-00			1	PROBE, package, P6006
2	103-0013-00			1	ADAPTER, 3 to 2 wire
3	161-0015-00	100	1672	1	CORD, power, AC
	161-0015-01	1673		1	CORD, power, AC
4	161-0016-00	100	1672	1	CORD, power, DC
	161-0016-01	1673		1	CORD, power, DC
5	012-0031-00	100	949	1	CORD, patch
	012-0091-00	950		2	CORD, patch, BNC to banana plug, 18 inches, red
6	103-0033-00	100	949X	1	ADAPTER, BNC to binding post
7	378-0547-00			1	FILTER, light, graticule
8	378-0577-00	X2508		1	FILTER, mesh (installed)
--	070-0425-00			2	MANUAL, instruction (not shown)

ELECTRICAL PARTS

Values are fixed unless marked Variable.

Ckt. No.	Tektronix Part No.	Description	S/N Range
Bulbs			
B424	150-027	Neon, NE-23	
B601	150-001	Incandescent, #47	Graticule Light
B602	150-001	Incandescent, #47	Graticule Light
B699	150-038	Assy w/GE 680 Lamp	LOW BATTERIES
B714	150-027	Neon, NE-23	
B845	150-020	Neon, FML-1-AFC-000	Pilot Light

Capacitors

Tolerance $\pm 20\%$ unless otherwise indicated.

Tolerance of all electrolytic capacitors as follows (with exceptions):

- 3 V — 50 V = -10% , $+250\%$
- 51 V — 350 V = -10% , $+100\%$
- 351 V — 450 V = -10% , $+50\%$

C2	281-501	4.7 pf	Cer	500 v	± 1 pf	
C8	283-008	0.1 μ f	Cer	500 v		
C20	283-003	0.01 μ f	Cer	150 v		
C23	281-518	47 pf	Cer	500 v	10%	
C30	290-026	5 μ f	EMT	25 v	-10%	$+75\%$
C37	281-516	39 pf	Cer	500 v	10%	
C43	281-549	68 pf	Cer	500 v	10%	
C131	281-549	68 pf	Cer	500 v	10%	
C141	281-516	39 pf	Cer	500 v	10%	
C147	281-589	167 pf	Cer	500 v	5%	
C160A } C160C } C160E } C160G } C160J }	*295-078	10 μ f 1 μ f 0.1 μ f 0.01 μ f 0.001 μ f	} Timing Series			
C160L	281-022	8-50 pf	Cer	Var		
C160M	Use 281-631	470 pf	Cer	1000 v	5%	100-3029
C160M	283-0148-00	470 pf	Cer	1000 v	5%	3030-up
C165	281-512	27 pf	Cer	500 v	10%	
C170	281-512	27 pf	Cer	500 v	10%	
C180A	290-121	2 μ f	EMT	25 v	-10%	$+150\%$
C180C	285-633	0.22 μ f	EMT	100 v	10%	
C180E	283-058	0.027 μ f	Cer	100 v	10%	
C180G	283-051	0.0033 μ f	Cer	100 v		
C181	281-524	150 pf	Cer	500 v		
C193	281-525	470 pf	Cer	500 v		

Parts List — Type 321A

Capacitors (Cont'd)

Ckt. No.	Tektronix Part No.		Description			S/N Range
C300	281-513	27 pf	Cer		500 v	
C311	281-501	4.7 pf	Cer		500 v	±1 pf
C312	Use 281-0506-00	12 pf	Cer		500 v	10%
C401	Use*285-0672-00	0.1 μf	PTM		600 v	
C410A	281-012	7-45 pf	Cer	Var		
C410C	281-005	1.5-7 pf	Cer	Var		
C410E	281-536	0.001 μf	Cer		500 v	10%
C410F	281-536	0.001 μf	Cer		500 v	10%
C412A	281-010	4.5-25 pf	Cer	Var		
C412C	281-005	1.5-7 pf	Cer	Var		
C412E	281-543	270 pf	Cer		500 v	10%
C414A	281-010	4.5-25 pf	Cer	Var		
C414C	281-007	3-12 pf	Cer	Var		
C414E	281-518	47 pf	Cer		500 v	
C416A	281-007	3-12 pf	Cer	Var		
C416C	281-007	3-12 pf	Cer	Var		
C418A	281-005	1.5-7 pf	Cer	Var		
C418C	281-010	4.5-25 pf	Cer	Var		
C422	281-534	3.3 pf	Cer			±0.25 pf
C423	283-041	0.0033 μf	Cer		500 v	5%
C436	283-059	1 μf	Cer		25 v	
C462	283-003	0.01 μf	Cer		150 v	
C472	283-003	0.01 μf	Cer		150 v	
C479	283-081	0.1 μf	Cer		25 v	
C483	283-010	0.05 μf	Cer		50 v	
C484	283-026	0.2 μf	Cer		25 v	
C504	281-516	39 pf	Cer		500 v	10%
C506	281-012	7-45 pf	Cer	Var		X850-up
C507	281-549	68 pf	Cer		500 v	10%
C508	281-549	68 pf	Cer		500 v	10%
C517	283-059	1 μf	Cer		25 v	X400-up
C522	283-059	1 μf	Cer		25 v	X400-up
C524	283-003	0.01 μf	Cer		150 v	
C612	Use 290-0086-00	2000 μf	EMC		30 v	
C621	Use *285-0672-00	0.1 μf	PTM		600 v	
C629	290-106	10 μf	EMT		15 v	
C654	283-000	0.001 μf	Cer		500 v	
C657	290-201	100 μf	EMT		15 v	
C660	290-218	500 μf	EMT		30 v	
C696	Use 290-0118-00	2 x 100 μf	EMC		50 v	
C701	283-001	0.005 μf	Cer		500 v	
C707	283-000	0.001 μf	Cer		500 v	
C714	283-034	0.005 μf	Cer		4000 v	
C715	283-034	0.005 μf	Cer		4000 v	
C716	283-022	0.02 μf	Cer		1400 v	
C717	283-034	0.005 μf	Cer		4000 v	
C718	283-013	0.01 μf	Cer		1000 v	
C719	285-575	0.1 μf	PTM		1000 v	
C720	283-034	0.005 μf	Cer		4000 v	
C724	283-000	0.001 μf	Cer		500 v	

Capacitors (Cont'd)

Ckt. No.	Tektronix Part No.		Description		S/N Range
C730	290-117	50 μ f	EMT	50 v	
C731	290-117	50 μ f	EMT	50 v	
C734	290-117	50 μ f	EMT	50 v	
C735	290-117	50 μ f	EMT	50 v	
C737	290-167	10 μ f	EMT	15 v	
C738	290-201	100 μ f	EMT	15 v	
C739	290-201	100 μ f	EMT	15 v	
C742	290-217	250 μ f	EMT	12 v	
C743	290-138	330 μ f	EMT	6 v	
C745	290-140	120 μ f	EMT	10 v	
C750	290-201	100 μ f	EMT	15 v	
C751	290-201	100 μ f	EMT	15 v	
C753	290-137	100 μ f	EMT	30 v	
C754	290-201	100 μ f	EMT	15 v	
C756	290-117	50 μ f	EMT	50 v	
C757	290-117	50 μ f	EMT	50 v	
C758	290-117	50 μ f	EMT	50 v	X400-up
C852	283-022	0.02 μ f	Cer	1400 v	
C854	283-013	0.01 μ f	Cer	1000 v	
C864	283-003	0.01 μ f	Cer	150 v	
C871	281-525	470 pf	Cer	500 v	
C874	290-114	47 μ f	EMT	6 v	

Diodes

D111	Use *152-185	Silicon	Replaceable by 1N3605		
D131	152-008	Germanium			
D144	Use *152-185	Silicon	Replaceable by 1N3605		
D145	Use *152-185	Silicon	Replaceable by 1N3605		
D148	Use *152-185	Silicon	Replaceable by 1N3605		
D149	Use *152-185	Silicon	Replaceable by 1N3605		
D150	152-008	Germanium			
D153	Use *152-185	Silicon	Replaceable by 1N3605		
D183	Use *152-185	Silicon	Replaceable by 1N3605		
D194	152-008	Germanium			
D443	152-008	Germanium			
D505	*152-075	Germanium	Tek Spec		
D506	*152-075	Germanium	Tek Spec		
D610	152-066	Silicon	1N3194		
D611	152-066	Silicon	1N3194		
D614	Use 152-008	Germanium			
D620	152-066	Silicon	1N3194		
D629	152-139	Zener	1N751	0.4 w, 5.1 v, 10%	
D660	152-066	Silicon	1N3194		

Parts List — Type 321A

Diodes (Cont'd)

Ckt. No.	Tektronix Part No.		Description	S/N Range
D661	152-066	Silicon	1N3194	
D692	152-066	Silicon	1N3194	
D700	152-001	Germanium	1N91	
D710	152-008	Germanium		100-399
D710	152-141	Silicon	1N3605	400-up
D711	152-008	Germanium		100-399
D711	152-141	Silicon	1N3605	400-up
D712	152-008	Germanium		100-399
D712	152-141	Silicon	1N3605	400-up
D713	152-008	Germanium		100-399
D713	152-141	Silicon	1N3605	400-up
D714	152-002	Silicon	1N1329	
D715	152-002	Silicon	1N1329	
D716	152-002	Silicon	1N1329	
D717	152-002	Silicon	1N1329	
D718	152-002	Silicon	1N1329	
D719	152-002	Silicon	1N1329	
D720	152-066	Silicon	1N3194	
D721	152-066	Silicon	1N3194	
D724	152-066	Silicon	1N3194	
D726	152-066	Silicon	1N3194	
D728	152-001	Germanium	1N91	
D882	Use *152-185	Silicon	Replaceable by 1N3605	

Fuses

F601	159-028	0.25 Amp	3AG	Fast Blo
F621	159-016	1.5 Amp	3AG	Fast Blo

Inductors

L24	*108-237	80 μ h		X400-up
L743	*108-200	40 μ h		
L745	*108-200	40 μ h		

Transistors

Q14	*151-133	Selected from 2N3251		
Q24	*151-133	Selected from 2N3251		
Q35	*151-108	Replaceable by 2N2501		
Q45	*151-126	Replaceable by 2N2484		
Q135	*151-108	Replaceable by 2N2501		
Q145	*151-108	Replaceable by 2N2501		
Q153	151-063	2N2207		
Q161	151-063	2N2207		
Q163	*151-126	Replaceable by 2N2484		
Q173	151-063	2N2207		

Transistors (Cont'd)

Ckt. No.	Tektronix Part No.	Description	S/N Range
Q183	151-063	2N2207	
Q194	151-063	2N2207	
Q199	151-071	2N1305	
Q313	151-063	2N2207	
Q323	151-063	2N2207	
Q334	151-063	2N2207	
Q344	151-063	2N2207	
Q443	151-063	2N2207	
Q453	151-063	2N2207	
Q464	151-063	2N2207	
Q474	151-063	2N2207	
Q484	*151-108	Replaceable by 2N2501	
Q494	*151-108	Replaceable by 2N2501	
Q504	151-063	2N2207	
Q514	151-063	2N2207	
Q519	151-063	2N2207	
Q524	*151-126	Replaceable by 2N2484	
Q614	151-063	2N2207	
Q624	151-136	2N3053	
Q634	151-136	2N3053	
Q654	*151-087	Selected from 2N1131	
Q657	151-101	2N2137	
Q700	151-101	2N2137	
Q710	151-101	2N2137	
Q874	*151-108	Replaceable by 2N2501	

Resistors

Resistors are fixed, composition, $\pm 10\%$ unless otherwise indicated.

R2	Use 315-913	91 k	1/4 w	5%	
R14	316-335	3.3 meg	1/4 w		X400-up
R15	316-103	10 k	1/4 w		
R17	311-345	20 k			Var
R19	316-472	4.7 k	1/4 w		LEVEL
R20	315-202	2 k	1/4 w	5%	
R23	315-473	47 k	1/4 w	5%	
R24	315-272	2.7 k	1/4 w	5%	
R25	316-681	680 Ω	1/4 w		
R32	323-232	2.55 k	1/2 w	Prec	1%
R33	323-276	7.32 k	1/2 w	Prec	1%
R34	323-333	28.7 k	1/2 w	Prec	1%
R35	315-332	3.3 k	1/4 w		5%
R37	315-433	43 k	1/4 w		5%
R38	315-103	10 k	1/4 w		5%
R43	323-251	4.02 k	1/2 w	Prec	1%

Parts List — Type 321A

Resistors (Cont'd)

Ckt. No.	Tektronix Part No.		Description		S/N Range
R46	315-183	18 k	1/4 w		5%
R110	316-682	6.8 k	1/4 w		
R111	311-159	20 k		Var	STABILITY
R113	316-562	5.6 k	1/4 w		
R131	316-392	3.9 k	1/4 w		
R133	302-821	820 Ω	1/2 w		
R134	316-102	1 k	1/4 w		
R135	315-103	10 k	1/4 w		5%
R141	315-393	39 k	1/4 w		5%
R143	315-184	180 k	1/4 w		5%
R144	315-393	39 k	1/4 w		5%
R147	316-153	15 k	1/4 w		
R148	315-621	620 Ω	1/4 w		5%
R151	315-102	1 k	1/4 w		5%
R152	316-273	27 k	1/4 w		
R153	315-330	33 Ω	1/4 w		5%
R160A	323-486	1.13 meg	1/2 w	Prec	1%
R160C	323-448	453 k	1/2 w	Prec	1%
R160E	322-419	226 k	1/4 w	Prec	1%
R160G	323-390	113 k	1/2 w	Prec	1%
R160J	323-352	45.3 k	1/2 w	Prec	1%
R160L	323-323	22.6 k	1/2 w	Prec	1%
R160R	316-223	22 k	1/4 w		
R160S	316-273	27 k	1/4 w		
R160T	316-473	47 k	1/4 w		
R160U	316-223	22 k	1/4 w		
R160V	311-166	20 k		Var	VARIABLE (Time/Div)
R160Z	316-473	47 k	1/4 w		
R161	316-151	150 Ω	1/4 w		
R162	316-186	18 meg	1/4 w		
R165	316-563	56 k	1/4 w		
R167	316-104	100 k	1/4 w		
R169	316-273	27 k	1/4 w		
R174	316-683	68 k	1/4 w		
R176	311-153	10 k		Var	SWEEP LENGTH
R177	316-103	10 k	1/4 w		
R178	316-272	2.7 k	1/4 w		
R181	316-104	100 k	1/4 w		
R182	316-153	15 k	1/4 w		
R183	316-333	33 k	1/4 w		
R190	316-103	10 k	1/4 w		
R193	316-151	150 Ω	1/4 w		
R194	316-223	22 k	1/4 w		
R196	316-331	330 Ω	1/4 w		
R197	316-333	33 k	1/4 w		

Resistors (Cont'd)

Ckt. No.	Tektronix Part No.		Description		S/N Range
R198	315-243	24 k	1/4 w		5%
R199	316-273	27 k	1/4 w		
R300	Use 322-365	61.9 k	1/4 w	Prec	1%
R301	323-442	392 k	1/2 w	Prec	1%
R302	315-684	680 k	1/4 w		5%
R311	323-348	41.2 k	1/2 w	Prec	1%
R312	323-286	9.31 k	1/2 w	Prec	1%
R316	323-346	39.2 k	1/2 w	Prec	1%
R317	316-472	4.7 k	1/4 w		
R322A } R322B }	311-429	100 k 10 k	Var }	VERNIER HORIZONTAL POSITION COARSE	
R323	316-392	3.9 k	1/4 w		
R324	316-183	18 k	1/4 w		
R325	315-103	10 k	1/4 w		5%
R326	315-103	10 k	1/4 w		5%
R327	316-472	4.7 k	1/4 w		
R328	321-177	681 Ω	1/8 w	Prec	1%
R333	323-289	10 k	1/2 w	Prec	1%
R336	323-308	15.8 k	1/2 w	Prec	1%
R338	311-328	1 k		Var	HORIZ GAIN
R343	323-286	9.31 k	1/2 w	Prec	1%
R346	323-308	15.8 k	1/2 w	Prec	1%
R347	321-117	162 Ω	1/8 w	Prec	1%
R348	311-461	250 Ω		Var	MAG GAIN
R410C	323-481	1 meg	1/2 w	Prec	1%
R410E	323-193	1 k	1/2 w	Prec	1%
R412C	323-614	990 k	1/2 w	Prec	1%
R412E	322-605	10.1 k	1/4 w	Prec	1%
R414C	323-611	900 k	1/2 w	Prec	1%
R414E	323-610	11 k	1/2 w	Prec	1%
R416C	323-620	800 k	1/2 w	Prec	1%
R416E	322-614	250 k	1/4 w	Prec	1%
R418C	322-610	500 k	1/4 w	Prec	1%
R418E	323-481	1 meg	1/2 w	Prec	1%
R420	316-470	47 k	1/4 w		
R422	323-481	1 meg	1/2 w	Prec	1%
R423	316-394	390 k	1/4 w		
R424	316-470	47 Ω	1/4 w		
R427	316-103	10 k	1/4 w		
R432	Use 311-387	5 k		Var	DC BAL
R434	323-329	26.1 k	1/2 w	Prec	1%
R435	301-514	510 k	1/2 w		5%
R436	323-221	1.96 k	1/2 w	Prec	1%
R437	322-298	12.4 k	1/4 w	Prec	1%
R443	316-682	6.8 k	1/4 w		
R453	316-682	6.8 k	1/4 w		

Parts List — Type 321A

Resistors (Cont'd)

Ckt. No.	Tektronix Part No.		Description			S/N Range
R454	315-223	22 k	1/4 w			5%
R455	311-346	2 x 20 k	0.2 w	Var		VERTICAL POSITION
R457	315-223	22 k	1/4 w			5%
R462	315-392	3.9 k	1/4 w			5%
R464	321-109	133 Ω	1/8 w		Prec	1%
R466	*311-477	780 Ω		Var	WW	VARIABLE
R468	311-258	100 Ω		Var		VERT GAIN
R472	315-392	3.9 k	1/4 w			5%
R476	323-284	8.87 k	1/2 w		Prec	1%
R478	323-284	8.87 k	1/2 w		Prec	1%
R479	323-221	1.96 k	1/2 w		Prec	1%
R482	323-233	2.61 k	1/2 w		Prec	1%
R483	323-197	1.1 k	1/2 w		Prec	1%
R484	323-231	2.49 k	1/2 w		Prec	1%
R489	323-221	1.96 k	1/2 w		Prec	1%
R492	323-233	2.61 k	1/2 w		Prec	1%
R494	323-231	2.49 k	1/2 w		Prec	1%
R502	323-245	3.48 k	1/2 w		Prec	1%
R504	321-107	127 Ω	1/8 w		Prec	1%
R505	321-081	68.1 Ω	1/8 w		Prec	1%
R506	315-151	150 Ω	1/4 w			5%
R509	323-146	324 Ω	1/2 w		Prec	1%
R511	323-146	324 Ω	1/2 w		Prec	1%
R512	323-245	3.48 k	1/2 w		Prec	1%
R516	323-160	453 Ω	1/2 w		Prec	1%
R517	323-223	2.05 k	1/2 w		Prec	1%
R519	323-200	1.18 k	1/2 w		Prec	1%
R520	321-381	90.9 k	1/8 w		Prec	1%
R521	321-318	20 k	1/8 w		Prec	1%
R522	321-333	28.7 k	1/8 w		Prec	1%
R522	321-331	27.4 k	1/8 w		Prec	1%
R523	321-204	1.3 k	1/8 w		Prec	1%
R524	316-222	2.2 k	1/4 w			100-399 400-up X400-up
R525	316-682	6.8 k	1/4 w			
R602	311-344	100 Ω		Var	WW	SCALE ILLUM
R610	308-175	10 Ω	10 w		WW	5%
R612	302-682	6.8 k	1/2 w			X171-up
R622	315-241	240 Ω	1/4 w			5%
R624	316-102	1 k	1/4 w			
R631	315-112	1.1 k	1/4 w			5%
R635	308-012	40 Ω	10 w		WW	5%
R644	316-470	47 Ω	1/4 w			
R650	323-202	1.24 k	1/2 w		Prec	1%
R651	311-380	500 Ω		Var	WW	10 V ADJ
R652	323-204	1.3 k	1/2 w		Prec	1%
R692	308-110	100 Ω	8 w		WW	5%
R693	308-174	117 Ω	8 w		WW	5%
R694	306-681	680 Ω	2 w			
R695	323-163	487 Ω	1/2 w		Prec	1%

Resistors (Cont'd)

Ckt. No.	Tektronix Part No.		Description			S/N Range
R696	323-163	487 Ω	1/2 w		Prec	1%
R697	323-204	1.3 k	1/2 w		Prec	1%
R699	302-101	100 Ω	1/2 w			
R700	316-331	330 Ω	1/4 w			
R701	302-100	10 Ω	1/2 w			
R707	316-223	22 k	1/4 w			
R714	302-104	100 k	1/2 w			
R718	316-105	1 meg	1/4 w			
R719	316-472	4.7 k	1/4 w			
R720	302-105	1 meg	1/2 w			
R731	316-101	100 Ω	1/4 w			100-399
R731	315-221	220 Ω	1/4 w			400-up
R735	316-471	470 Ω	1/4 w			
R737	316-560	56 Ω	1/4 w			
R739	316-390	39 Ω	1/4 w			100-399
R739	315-330	33 Ω	1/4 w			400-up
R751	316-470	47 Ω	1/4 w			
R753	316-331	330 Ω	1/4 w			
R754	316-221	220 Ω	1/4 w			100-399
R754	315-121	120 Ω	1/4 w			400-up
R757	316-101	100 Ω	1/4 w			100-399
R757	315-0181-00	180 Ω	1/4 w			400-up
R758	316-100	10 Ω	1/4 w			X400-up
R841	301-225	2.2 meg	1/2 w			5%
R842	311-349	2 meg	0.2 w	Var		FOCUS
R843	301-624	620 k	1/2 w			5%
R844	311-451	500 k		Var		INTENSITY
R844	311-0589-00	250 k		Var		INTENSITY
R848	301-156	15 meg	1/2 w			5%
R849	301-186	18 meg	1/2 w			5%
R851	316-105	1 meg	1/4 w			
R854	302-105	1 meg	1/2 w			
R861	311-157	100 k		Var		GEOM ADJ
R864	311-347	100 k	0.2 w	Var		ASTIGMATISM
R871	316-104	100 k	1/4 w			
R874	316-151	150 Ω	1/4 w			
R881	316-222	2.2 k	1/4 w			
R882	323-272	6.65 k	1/2 w			
R884	311-323	1.5 k		Var		
R886	321-169	562 Ω	1/8 w		Prec	1%
R887	316-274	270 k	1/4 w		Prec	1%
R888	321-067	48.7 Ω	1/8 w		Prec	1%

Switches

	Unwired	Wired		
SW2	260-449		Slide	INT-EXT
SW8	260-449		Slide	AC-DC
SW15	260-447		Slide	SLOPE
SW17	260-296 *262-662		Rotary	AUTO (Level)

Parts List — Type 321A

Switches (Cont'd)

Ckt. No.	Tektronix Part No.		Description	S/N Range
	Unwired	Wired		
SW160 } SW348 }	260-376	*262-660	Rotary	TIME/DIV X 5 MAG
SW401	260-448		Slide	AC-DC-GND
SW410	260-625	*262-661	Rotary	VOLTS/DIV
SW621	260-617		Rotary	POWER
SW692	260-450		Slide	CHARGER
TK621	260-611		Thermal Cutout	155°F ±8°F

Transformers

T601	*120-152	Power
T701	*120-210	Converter

Electron Tubes

V423	Use*154-0306-02	7586, Aged
V859		*154-433

IMPORTANT

All circuit voltages were obtained with a 20,000 Ω/v VOM.
All readings are in volts.

Actual photographs of waveforms are shown.

Voltage and waveform measurements may vary due to normal component tolerances. Measurements were obtained by setting up the Type 321A for the following general conditions:

AC line voltage	Design center (115 v or 230 v)
POWER	ON EXT
Charger switch	DRY CELLS
FOCUS	Midrange
ASTIGMATISM	Midrange
INTENSITY	Midrange
TIME/DIV	.2 MILLI SEC
VARIABLE (TIME/DIV)	CALIB
5X MAG knob	Pushed in
TRIGGERING	
INT-EXT	INT
AC-DC	AC
SLOPE	+
VARIABLE (VOLTS/DIV)	CALIB
AC-DC-GND	GND

Refer to the schematic diagram of the circuit being checked to find the remaining conditions under which voltage and waveform measurements were obtained.

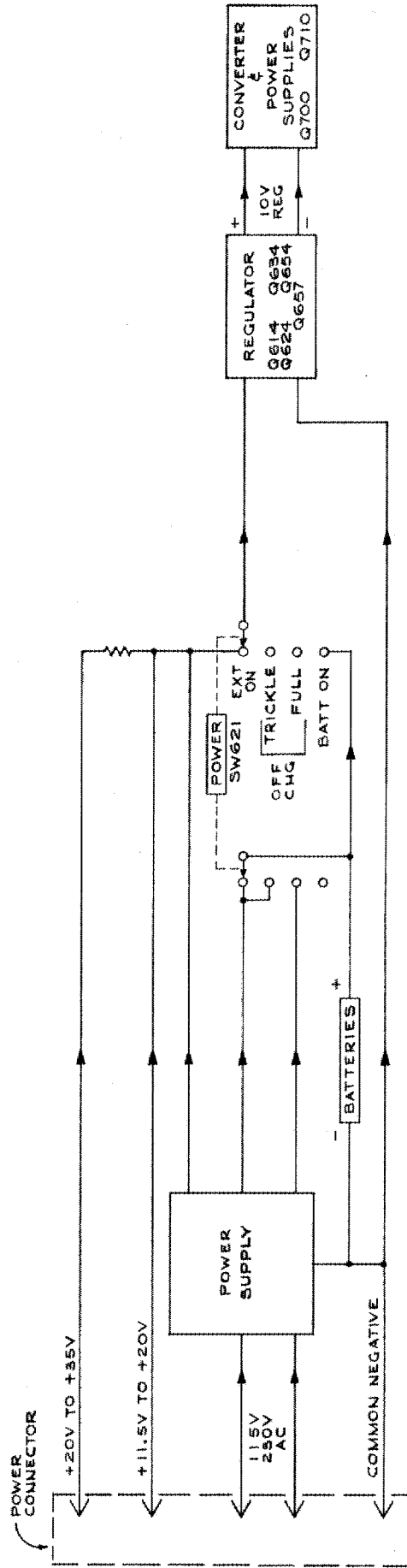
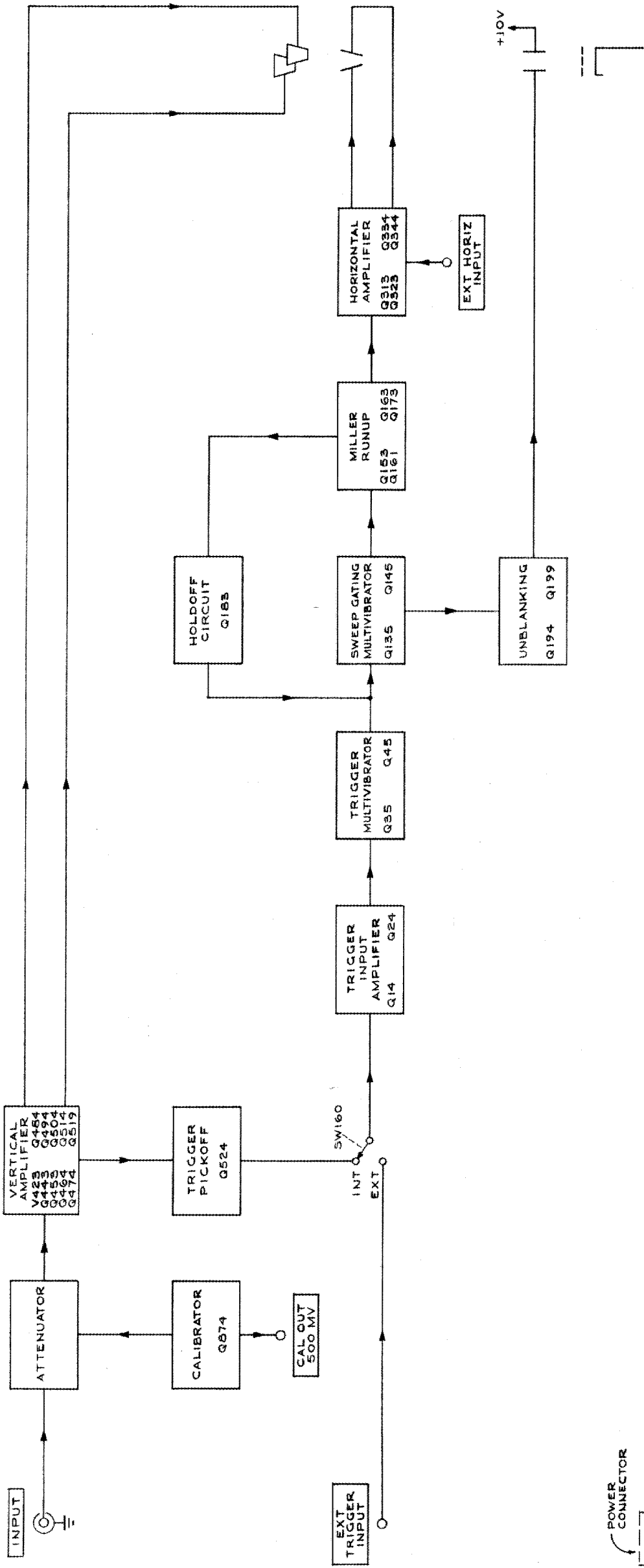

VERTICAL AMPLIFIER & CALIBRATOR

Quiescent VOLTAGE READINGS were obtained with controls set as follows:

VOLTS/DIV	1
VERTICAL POSITION	ccw (upper readings) cw (lower readings)

WAVEFORMS were obtained with controls set as follows:

VERTICAL POSITION	Midrange
VOLTS/DIV	CAL 4 DIV

Also, see IMPORTANT note on Block diagram.

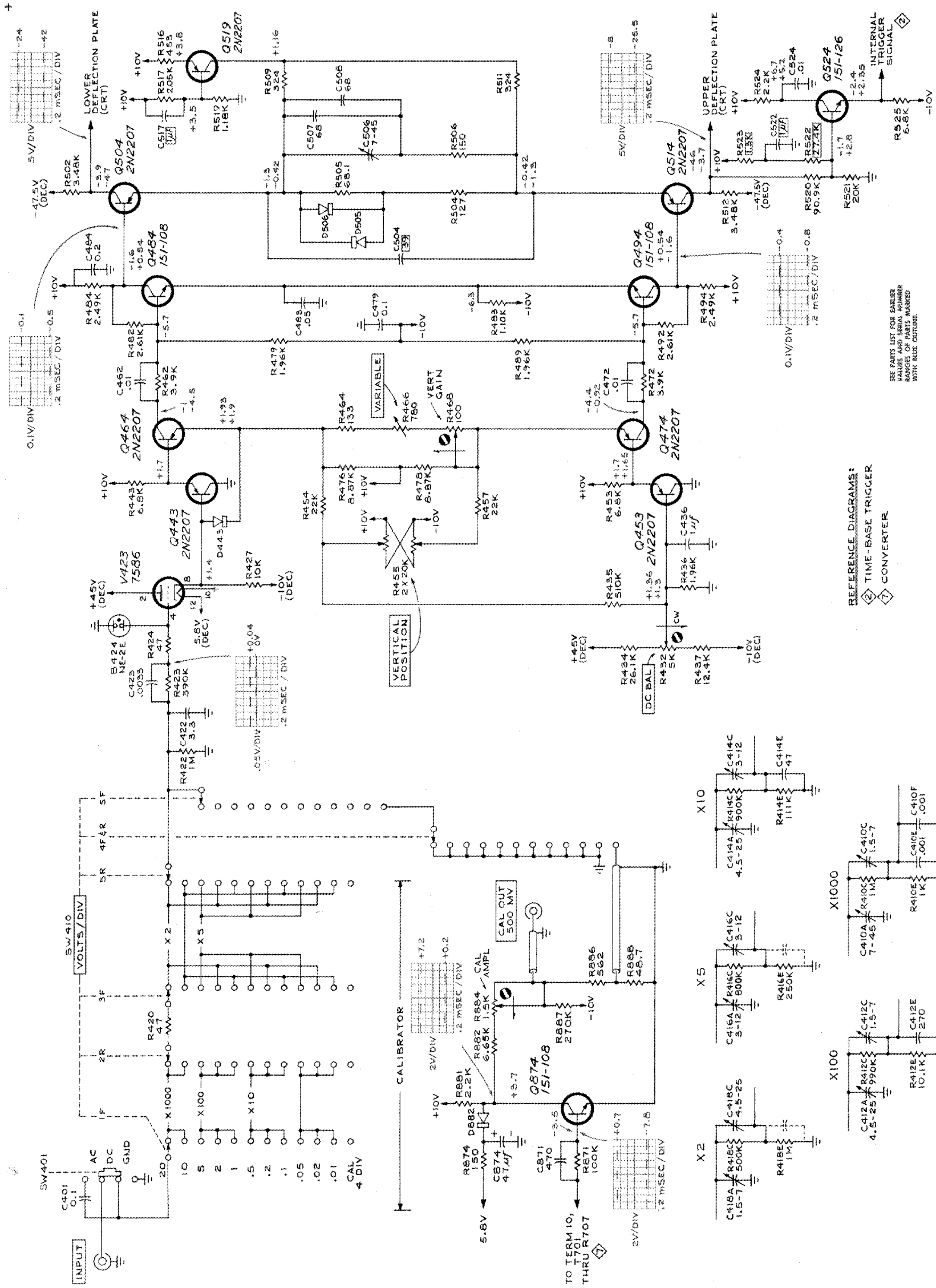

REFERENCE DIAGRAMS:
 ② TIME-BASE TRIGGER
 ⑦ CONVERTER

SEE PARTS LIST FOR EARLIER
 VALUES AND SERIAL NUMBER
 RANGES OF PARTS MARKED
 WITH BLUE OUTFITTING

VERTICAL AMPLIFIER & CALIBRATOR ①

MRH
 1164

C

ATTENUATOR DETAILS

TYPE 321A OSCILLOSCOPE

+

TIME-BASE TRIGGER

VOLTAGE & WAVEFORM dynamic measurements were obtained with controls set as follows:

TRIGGERING LEVEL

AUTO

VOLTS/DIV

CAL 4 DIV

Also, see IMPORTANT note on Block diagram.

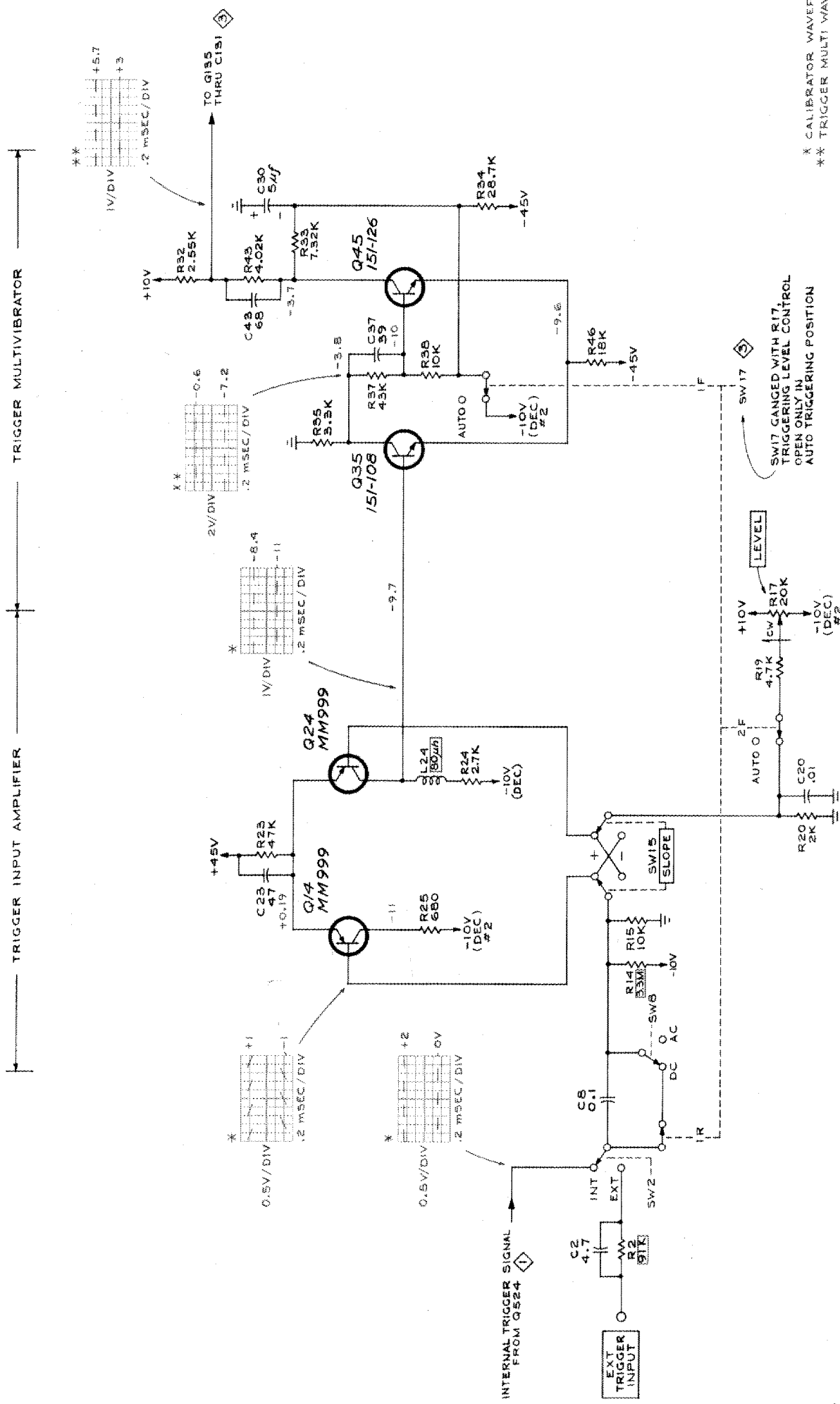

REFERENCE DIAGRAMS:
 ◊ VERTICAL AMPLIFIER & CALIBRATOR
 ◻ TIME-BASE GENERATOR

* CALIBRATOR WAVEFORM
 ** TRIGGER MULTI WAVEFORM

SW17 GANGED WITH R17, TRIGGERING LEVEL CONTROL OPEN ONLY IN AUTO TRIGGERING POSITION

TYPE 321A OSCILLOSCOPE

D

MR14
 1164
 TIME-BASE TRIGGER ◻

TIME-BASE GENERATOR

Quiescent VOLTAGE READINGS were obtained with controls set as follows:

VOLTS/DIV	CAL 4 DIV
TRIGGERING LEVEL	30° cw from AUTO (sweep not triggered)

WAVEFORMS were obtained with controls set as follows:

VOLTS/DIV	CAL 4 DIV
TRIGGERING LEVEL	AUTO

Also, see IMPORTANT note on Block diagram.

+

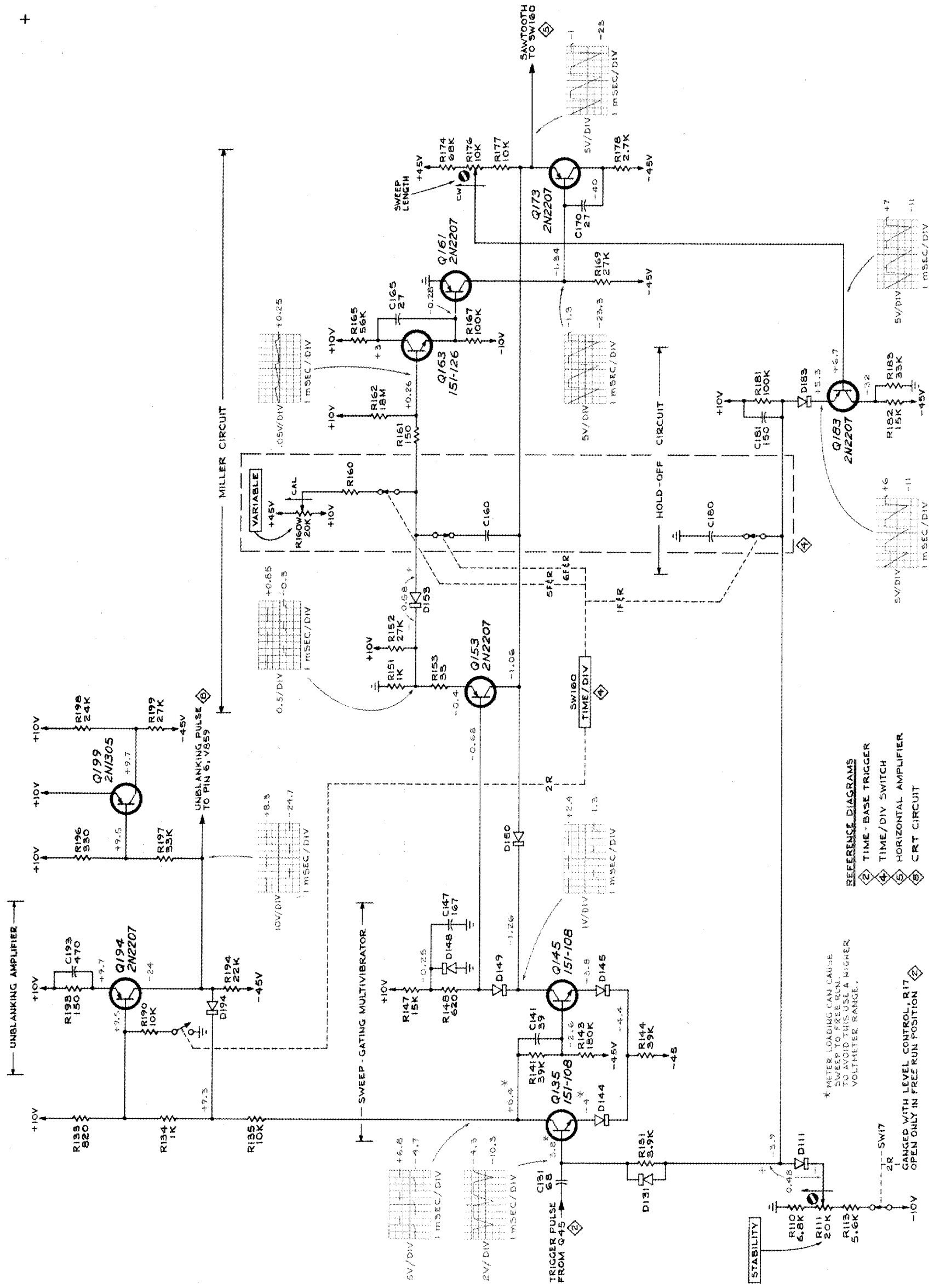

- REFERENCE DIAGRAMS
- 1 TIME-BASE TRIGGER
 - 2 TIME-DIV SWITCH
 - 3 HORIZONTAL AMPLIFIER
 - 4 CRT CIRCUIT

* METER LOADING CAN CAUSE SWEEP TO FREE RUN. TO AVOID THIS USE A HIGHER VOLTMETER RANGE.

+

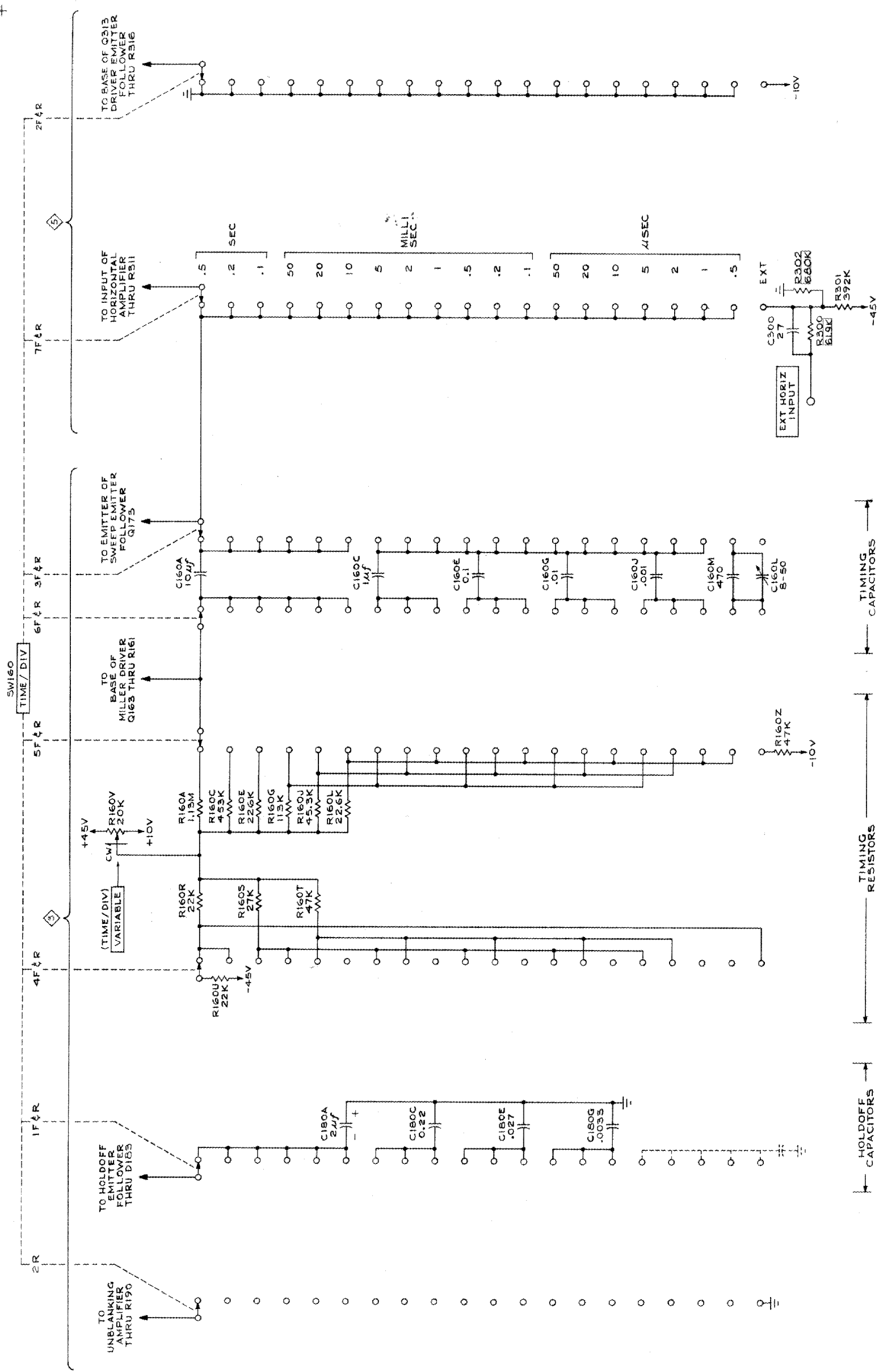

REFERENCE DIAGRAMS
 ③ TIME-BASE GENERATOR
 ④ HORIZONTAL AMPLIFIER

SEE PARTS LIST FOR EARLIER VALUES AND SERIAL NUMBER RANGES OF PARTS MARKED WITH BLUE OUTLINE.

TYPE 321A OSCILLOSCOPE

B

MR4
 465
 TIME / DIV SWITCH ④

HORIZONTAL AMPLIFIER

Quiescent VOLTAGE READINGS were obtained with controls set as follows:

VOLTS/DIV	CAL 4 DIV
TRIGGERING LEVEL	30° cw from AUTO (sweep not triggered)
HORIZONTAL POSITION	ccw (upper readings) cw (lower readings)

WAVEFORMS were obtained with controls set as follows:

VOLTS/DIV	CAL 4 DIV
TRIGGERING LEVEL	AUTO
HORIZONTAL POSITION	Midrange

Also, see IMPORTANT note on Block diagram.

HORIZONTAL AMPLIFIER

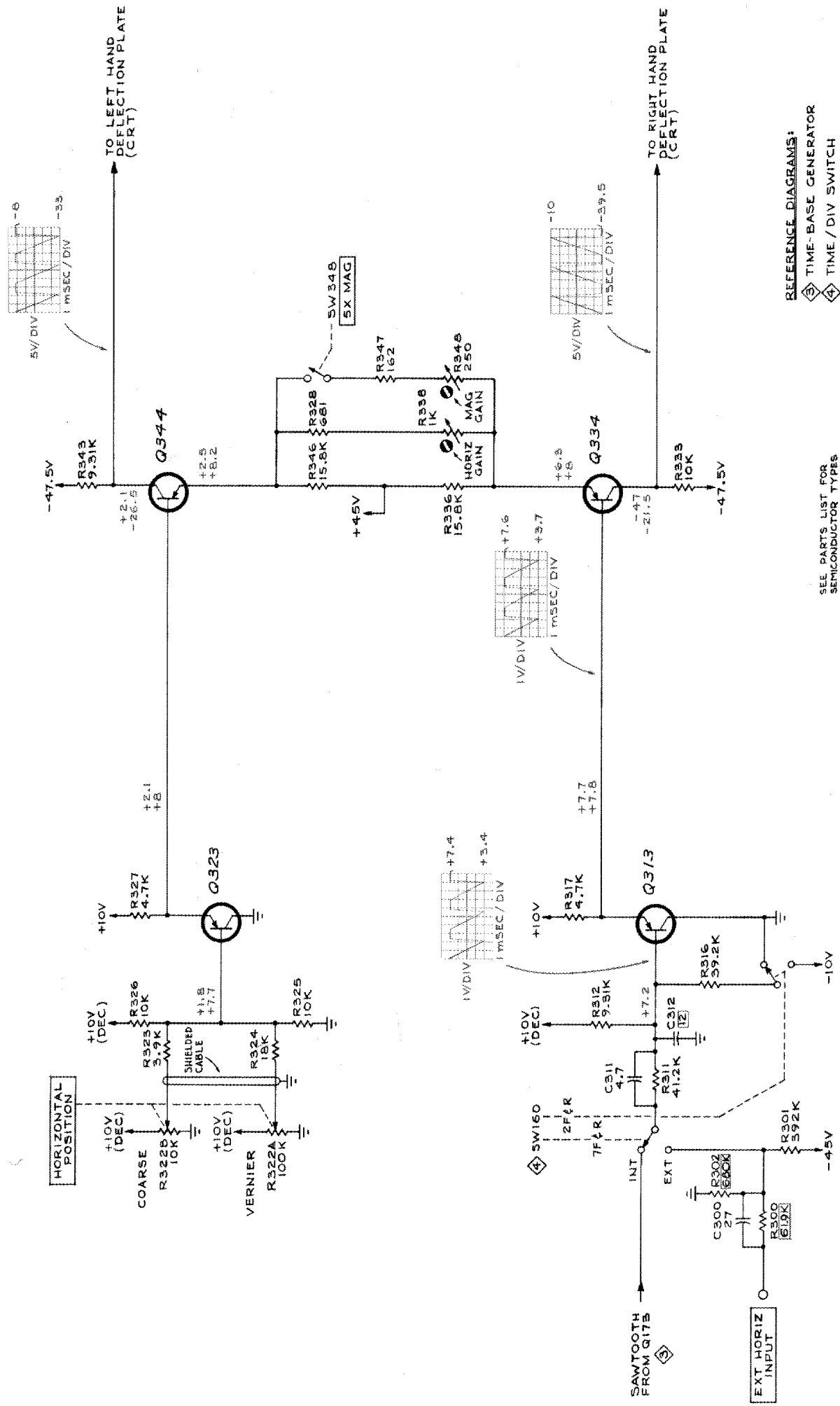

SEE PARTS LIST FOR SEMICONDUCTOR TYPES

REFERENCE DIAGRAMS:
 ③ TIME-BASE GENERATOR
 ④ TIME / DIV SWITCH

MRH
 965
 HORIZONTAL AMPLIFIER ⑤

SEE PARTS LIST FOR EARLIER
 MANUFACTURE PARTS MARKED
 WITH BLUE OUTLINE

TYPE 321A OSCILLOSCOPE

REGULATOR

VOLTAGE READINGS were taken with VOM negative lead connected to COMMON NEGATIVE bus.

Also, see IMPORTANT note on Block diagram.

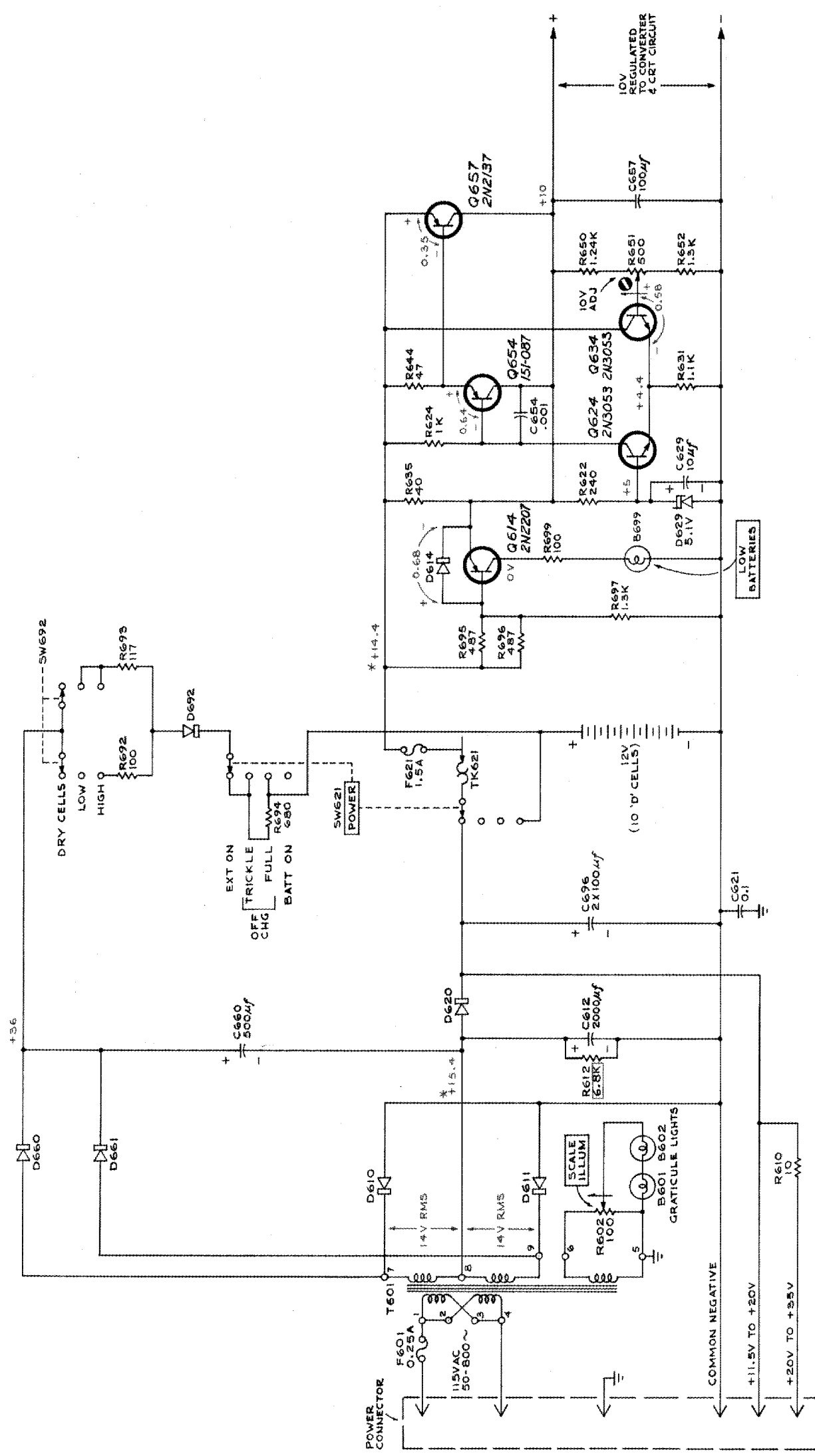

SEE PARTS LIST FOR EARLIER
VALUES AND SERIAL NUMBER
RANGES OF PARTS MARKED
WITH BLUE OUTLINE.

* VARIES WITH LINE VOLTAGE

MRH
B64
REGULATOR CIRCUIT 6

TYPE 321A OSCILLOSCOPE

B

CONVERTER

WAVEFORMS were taken after inserting a 3-to-2 wire line cord adapter in series with the Type 321A ac power cord to reduce hum modulation. If hum modulation is not reduced when using an adapter, unplug the adapter from the line, turn the plug 180° and reinsert it into the line.

See IMPORTANT note on Block diagram.

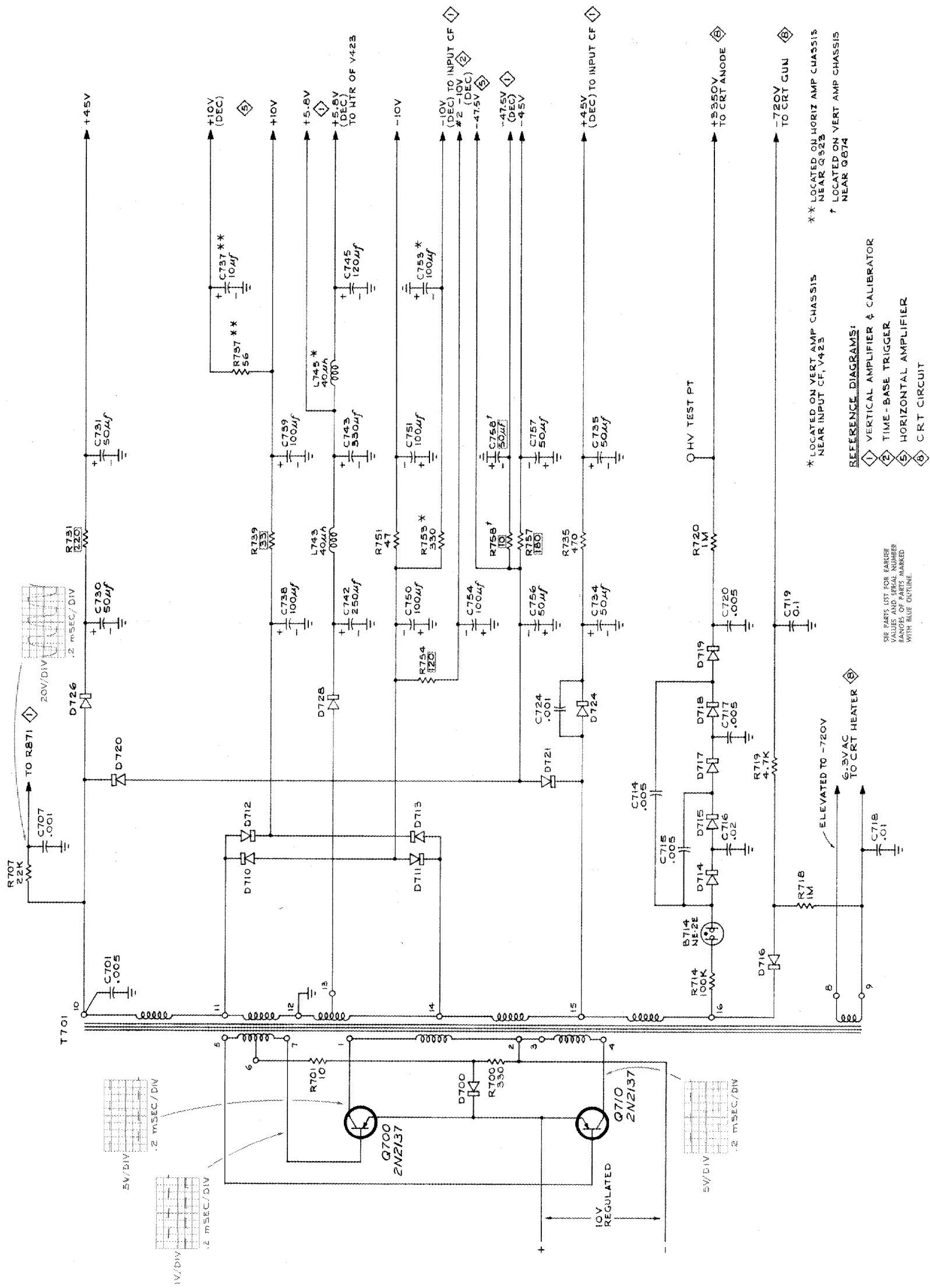

TYPE 321A OSCILLOSCOPE

CONVERTER 7

MRH
1164

C

SEE PARTS LIST FOR PARTS
VALUES AND SERIAL NUMBERS
RANGES OF PARTS MARKED
WITH BLUE OUTLINE.

* LOCATED ON VERT AMP CHASSIS
NEAR INPUT CF, V423

** LOCATED ON HORIZ AMP CHASSIS
NEAR Q523

† LOCATED ON VERT AMP CHASSIS
NEAR Q874

REFERENCE DIAGRAMS:
1 VERTICAL AMPLIFIER & CALIBRATOR
2 TIME-BASE TRIGGER
3 HORIZONTAL AMPLIFIER
4 CRT CIRCUIT

CRT

See IMPORTANT note on Block diagram.

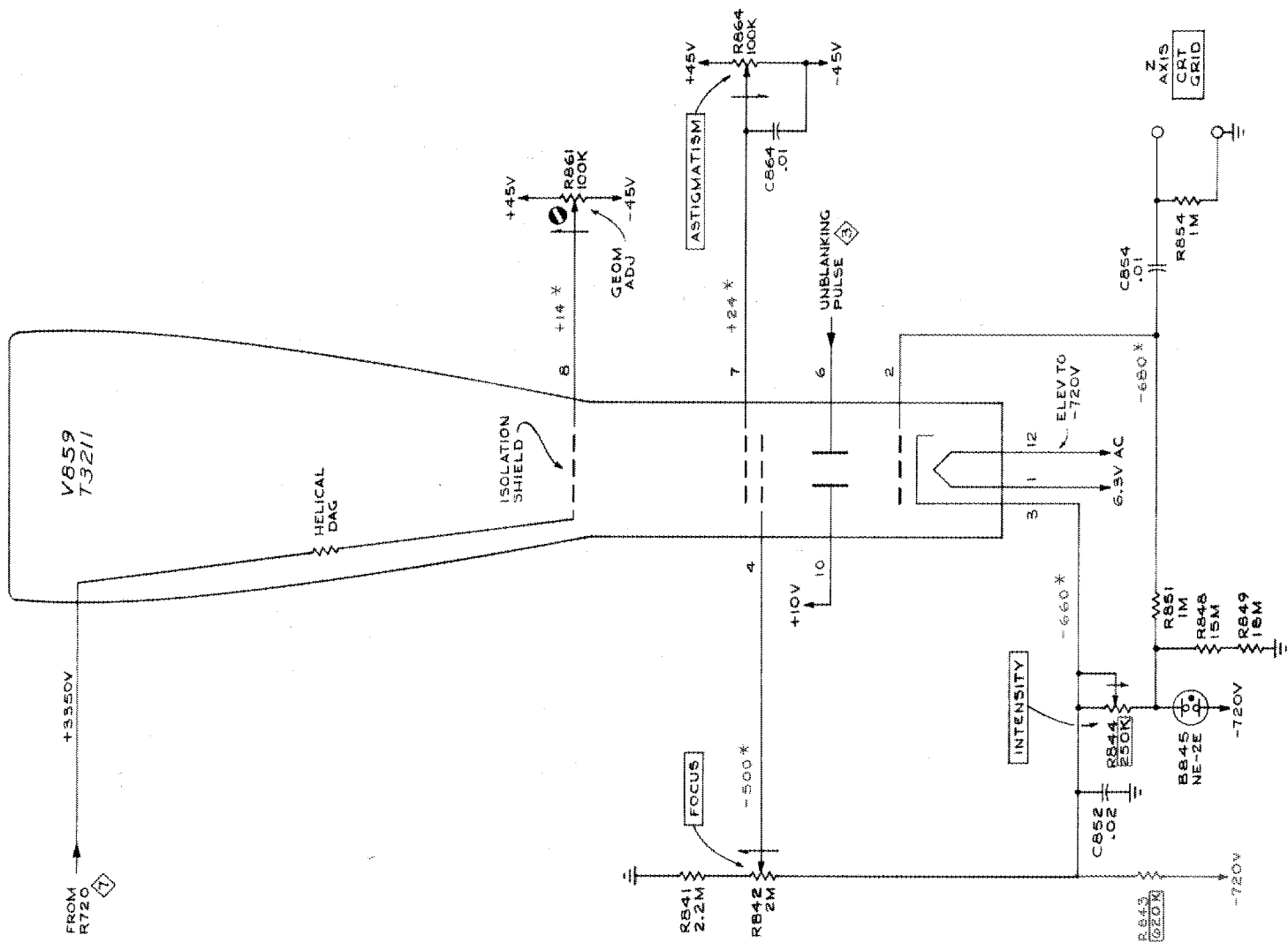

* DEPENDENT ON CONTROL SETTING & METER LOADING

REFERENCE DIAGRAMS
 3 TIME-BASE GENERATOR
 7 CONVERTER

SEE PARTS LIST FOR PARTS VALUES AND SERIAL NUMBER RANGES OF PARTS MARKED WITH BLUE OUTLINE

TYPE 321A OSCILLOSCOPE

MRH 1265
 CRT CIRCUIT 8

MANUAL CHANGE INFORMATION

At Tektronix, we continually strive to keep up with latest electronic developments by adding circuit and component improvements to our instruments as soon as they are developed and tested.

Sometimes, due to printing and shipping requirements, we can't get these changes immediately into printed manuals. Hence, your manual may contain new change information on following pages. If it does not, your manual is correct as printed.

PARTS LIST CORRECTION

CHANGE TO:

R410C	323-0481-01	1 MΩ	1/2 W	1/2%
R410E	323-0193-01	1 kΩ	1/2 W	1/2%
R412C	323-0614-01	990 kΩ	1/2 W	1/2%
R412E	322-1289-01	10.1 kΩ	1/2 W	1/2%
R414C	323-0611-01	900 kΩ	1/2 W	1/2%
R414E	323-1389-01	111 kΩ	1/2 W	1/2%
R416C	323-0620-01	800 kΩ	1/2 W	1/2%
R416E	322-0614-01	250 kΩ	1/4 W	1/2%
R418C	322-0610-01	500 kΩ	1/4 W	1/2%
R418E	323-0481-01	1 MΩ	1/2 W	1/2%
R422	323-0481-01	1 MΩ	1/2 W	1/2%

TYPE 321A TENT SN 3030

PARIS LIST CORRECTION

CHANGE TO:

C160M

283-0148-00

470 pF

Cer

5%

TYPE 321A TENT SN 3130

MECHANICAL PARTS LIST CORRECTION

Page 7-14, STANDARD ACCESSORIES,

Change REF. NO. 1 to read:

010-0203-00

1 PROBE, package, P6012

TYPE 321A

TENT SN 3290

PARTS LIST CORRECTION

ADD:

D151	152-0185-00	Silicon	6185	
R160K	316-0186-00	18 meg	1/4 w	10 %

SCHEMATIC CORRECTION

R160K is added in parallel with R160J.

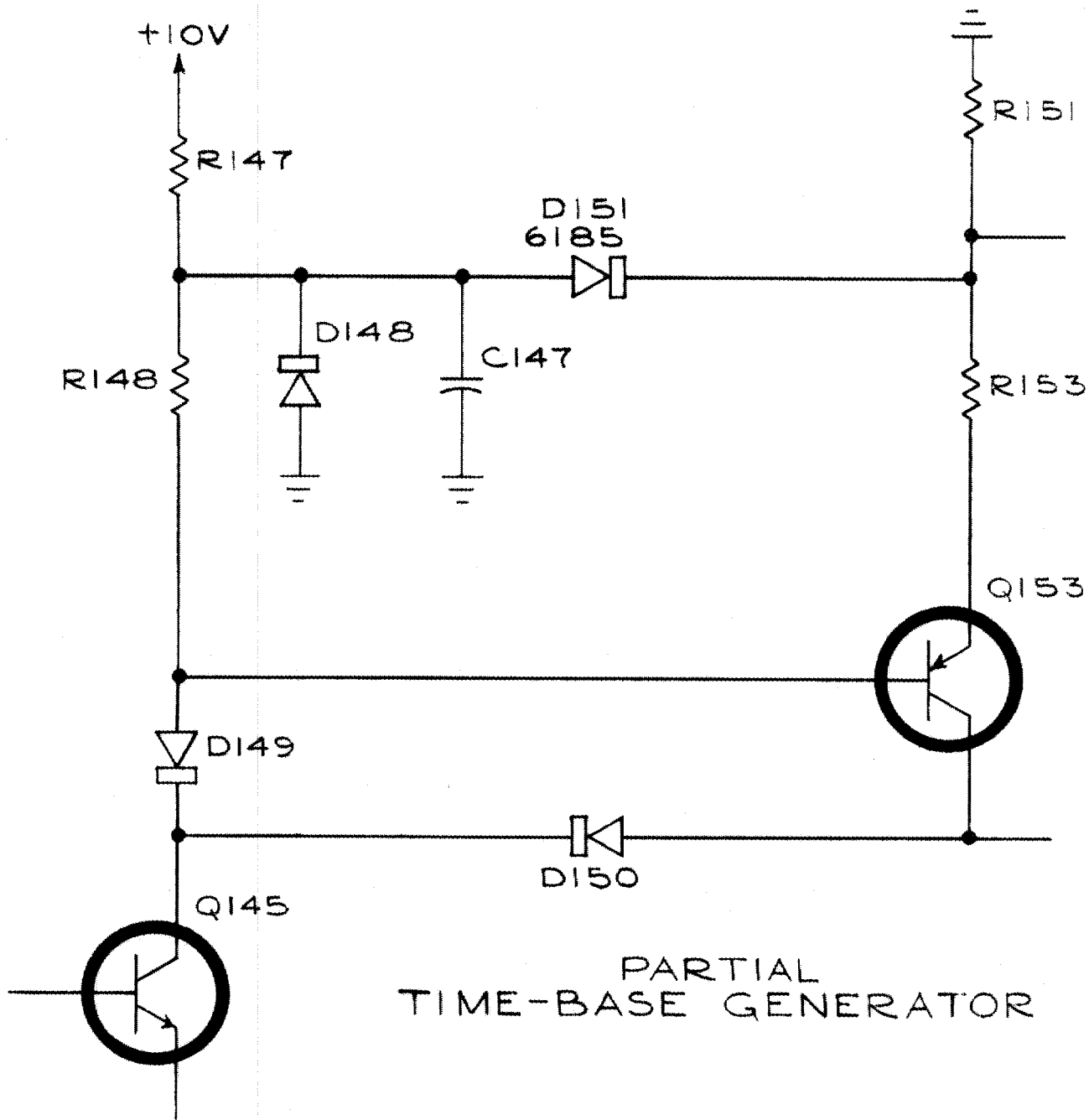

TYPE 321A

DC-to-6 MHz PORTABLE OSCILLOSCOPE

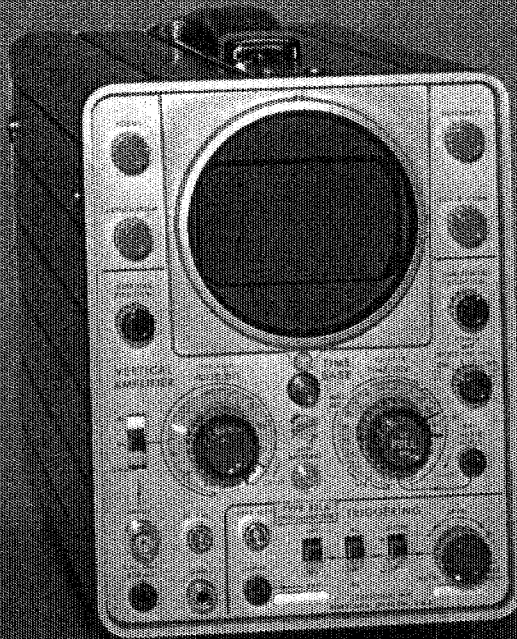

- 6-MHz BANDWIDTH AT 10 mV/DIV
- SMALL SIZE—LIGHT WEIGHT
- ALL SOLID-STATE DESIGN
- LOW POWER CONSUMPTION
- AC, DC, OR BATTERY OPERATED
- UP TO 8-HOURS OPERATION FROM INTERNAL BATTERIES
- DESIGNED FOR SEVERE ENVIRONMENTS

The Type 321A is a high-performance DC-to-6 MHz Oscilloscope. Its rugged mechanical and electrical design plus a choice of power options make it ideal for field operations requiring accurate waveform measurements. FET inputs provide low drift and fast stabilization time. With internal batteries, it weighs 17½ pounds; without batteries, it weighs 14 pounds.

CHARACTERISTIC SUMMARY

VERTICAL

BANDWIDTH—DC to 6 MHz.

RISETIME—58 ns

CALIBRATED DEFLECTION FACTOR—10 mV/div to 20 V/div, DC coupled.

INPUT RC—1 megohm paralleled by approx 35 pF.

HORIZONTAL

CALIBRATED TIME BASE—0.5 μ s/div to 0.5 s/div.

X5 MAGNIFIER—Extends time base to 0.1 μ s/div.

EXTERNAL INPUT—1 V/div, DC to 1 MHz.

CRT

DISPLAY AREA—6 x 10 div. Each div equal to ¼ inch.

ACCELERATING VOLTAGE—4 kV.

PHOSPHOR—P31

OTHER

AMPLITUDE CALIBRATOR—500-mV squarewave peak to peak and internal 40-mV squarewave peak to peak at approx 2 kHz.

POWER OPTIONS—10 size D batteries; external DC supply 11.5 to 35 V, \leq 700 mA; 115 VAC \pm 10% or 230 VAC \pm 10% 45 to 800 Hz, 20 W.

from 1969 Catalog

VERTICAL DEFLECTION

BANDWIDTH

DC to 6 MHz at 3-dB down. Low-frequency 3-dB-down point with AC coupling is ≤ 2 Hz, extended to ≤ 0.2 Hz when using the included 10X probe.

RISETIME

≤ 58 ns.

DEFLECTION FACTOR

10 mV/div to 20 V/div in 11 calibrated steps (1-2-5 sequence), accurate within 3%. Uncalibrated, continuously variable between steps and to approx 50 V/div.

INPUT RC

1 megohm within 2%, paralleled by 41 pF within 6 pF.

MAXIMUM INPUT VOLTAGE

500 V (DC + peak AC), < 500 V P-P AC.

HORIZONTAL DEFLECTION

TIME BASE

0.5 μ s/div to 0.5 s/div in 19 calibrated steps (1-2-5 sequence), accurate within 3% over center 8 divisions. Uncalibrated, continuously variable between steps and to approx 1.5 s/div.

X5 MAGNIFIER

Extends all time base steps, the fastest to 0.1 μ s/div. Magnified display accurate within 5% over center 8 divisions.

EXTERNAL INPUT

1 V/div $\pm 10\%$ with X5 magnifier. DC to ≥ 1 MHz at -3 dB. Input RC 100 k Ω within 5% paralleled by 25 pF within 5 pF.

TRIGGER

MODES

Automatic or manual level selection, or free run. Automatic operation is useful above 50 Hz, minimizes trigger adjustment for signals of different amplitudes, shapes, and repetition rates. With no input, automatic triggering occurs at an approx 50-Hz rate, providing a convenient reference trace.

COUPLING

AC or DC

SOURCES

Internal or external. External trigger input RC 100 k Ω within 20% paralleled by 9 pF within 4 pF.

REQUIREMENTS

0.2-div deflection or 1 V external from DC to 1 kHz, increasing to 1-div deflection or 3 V external at 6 MHz. Requirements increase below 1 kHz for internal AC coupled triggering, and below approx 30 Hz with external AC-coupled triggering.

CRT

TEKTRONIX CRT

6 x 10-div display area; each div is $\frac{1}{4}$ inch. 3-inch tube provides bright trace, utilizes low heater power. 4-kV accelerating potential. P31 phosphor normally supplied; P2, P7, or P11 are optional without extra charge. Consult your Field Engineer, Representative, or Distributor for application information and availability. Z-axis input is AC coupled, 5 V P-P at 1 kHz gives visible trace modulation at normal intensity.

GRATICULE

External; variable edge lighting when instrument is operated from AC line. Vertical and horizontal centerlines marked in 5 minor divisions per major $\frac{1}{4}$ -inch division.

ENVIRONMENTAL CAPABILITIES

AMBIENT TEMPERATURE

Operating (without batteries) -15°C to $+55^{\circ}\text{C}$.
Operating (with batteries installed) Charge Range, 0°C to $+40^{\circ}\text{C}$; Discharge Range, -15°C to 40°C .
Non-operating (without batteries) -55°C to $+75^{\circ}\text{C}$.
Non-operating (with batteries installed) -40°C to $+60^{\circ}\text{C}$.

ALTITUDE

Operating: 15,000 ft max.
Non-operating: 50,000 ft max.

VIBRATION

Operating: 15 minutes along each of 3 axes at 0.025 in peak to peak displacement (4 g's at 55 c/s), 10 to 55 to 10 c/s in 1-minute cycles.

SHOCK

Operating: 20 g's, $\frac{1}{2}$ sine, 11-ms duration. Two guillotine-type shocks per axis each direction for a total of 12 shocks.
Non-operating: 60 g's, $\frac{1}{2}$ sine, 11-ms duration. One guillotine-type shock per axis each direction for a total of 6 shocks.

HUMIDITY

Non-operating: Meets electrical performance specifications after exposure to five cycles (120 hours) of Mil-Std-202C, Method 106B (omit freezing and vibration, and allow a post-test drying period at $+20^{\circ}\text{C}$ and 25% to 80% relative humidity).

OTHER CHARACTERISTICS

AMPLITUDE CALIBRATOR

500 mV at external jack; accurate within 3% throughout operating range. 40 mV applied internally to vertical amplifier; accurate within 2% throughout operating range. ≤ 1 - μ s rise-time; 2 kHz $\pm 20\%$ repetition rate; 45% to 55% duty cycle.

POWER OPTIONS

Wired for 115 V RMS $\pm 10\%$, 45 to 800 Hz; tapped transformer also allows operation at 230 V $\pm 10\%$; 20-W maximum power consumption for oscilloscope only, 30-W maximum with internal batteries under full charge. Operates on external DC supply from 11.5 to 35 V DC; draws ≤ 600 mA. Operates on 10 internal size D batteries. NiCd rechargeable cells provide approx 8 hours continuous operation. Front-panel light indicates when internal batteries are low, or (using external power) when the voltage source drops too low for proper power supply regulation. Recharge requires at least 16 hours.

BATTERY CHARGER

Internal charger provides two different charging currents to the internal batteries. A trickle charge or a full charge is applied to the internal batteries when the instrument is turned off, but connected to the AC line.

TYPE 321A

DIMENSIONS AND WEIGHTS

Height	8¾ in	22.2 cm
Width	5¾ in	14.6 cm
Depth	16½ in	41.9 cm
Net weight	14¼ lb	6.5 kg
Domestic shipping weight	≈22 lb	≈10.0 kg
Export packed weight	≈33 lb	≈15.0 kg

INCLUDED STANDARD ACCESSORIES

P6012 10X probe (010-0203-00); two 18-inch BNC-to-banana plug patch cords (012-0091-00); DC power cord (161-0016-01); AC power cord (161-0015-01); 3 to 2-wire adapter (103-0013-00); smoke-gray light filter (378-0547-00); mesh filter, installed (378-0577-00); two instruction manuals (070-0425-00).

TYPE 321A OSCILLOSCOPE, without batteries \$975

OPTIONAL ACCESSORIES

Optional accessories increase measurement capability and provide added convenience. The standard 10X probe supplied with the instrument satisfies most measurement requirements; optional probes may be better suited for particular applications. In addition to the listed optional probes, other probes are available for current and high-voltage measurements. See catalog accessory pages for additional information on these and other items.

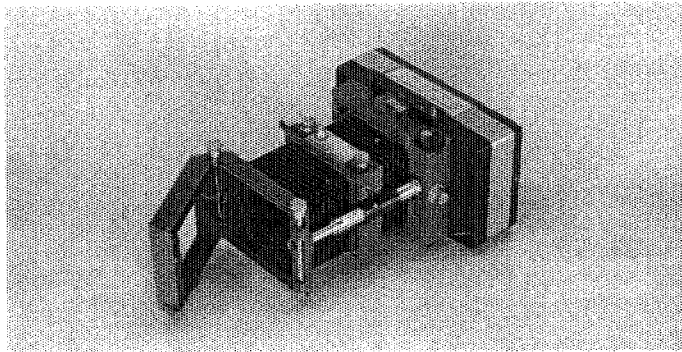

C-30A COMPACT CAMERA

f/1.9 lens, magnification variable from 1.5:1 to 0.7:1, Polaroid Land* Pack-Film back for 3000-speed film, order C-30A-P . . . \$450
 321A to C-30A Camera adapter, order 016-0242-00 . . . \$ 15

*Registered Trademark Polaroid Corporation

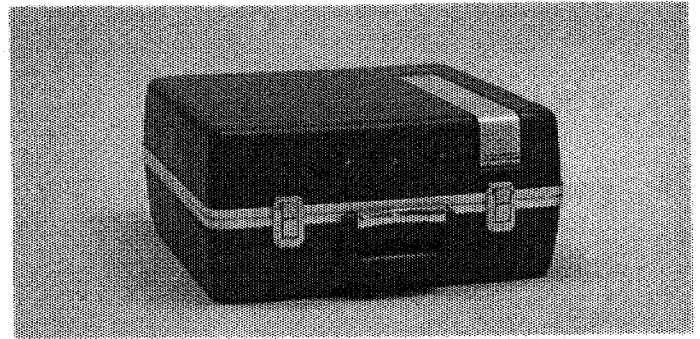

C-30A CAMERA CARRYING CASE

Constructed of heavy-gage, high-impact plastic, has foam-backed, vacuum-formed styrene liner. Holds C-30A Camera, all standard accessories and extra film.
 Order 016-0126-00 \$ 35

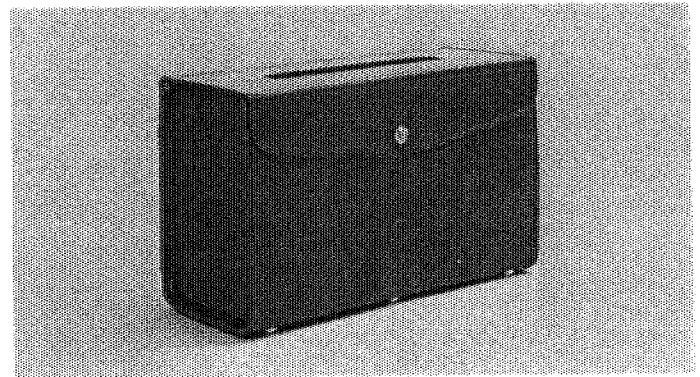

CARRYING CASE

Protects Type 321A, provides convenient accessory storage compartment, order 016-0026-00 \$38

RECHARGEABLE BATTERIES

Each NiCd cell, order 146-0010-00 \$ 7
 Set of 10 NiCd cells, order 016-0077-01 \$ 70

PROBES

P6007 100X Probe Package, order 010-0150-00 \$26
 P6011 1X Miniature-Probe Package, order 010-0193-00 . . \$19

U.S. Sales Prices FOB Beaverton, Oregon
 Please refer to Terms and Shipment, General Information page.

Power Cords same as 4L2 with battery option.